

Nonprofit Leader Reminds Teen Moms They Can Persevere, Pens Candid Book



(Left to right) Jazlyn Johnson, Leanna Braun, Brittany Ballinger, Jasmine Bowers and Ashley Ballinger participated in a celebratory gathering at Pip Moyer Recreation Center in Annapolis, Maryland on January 14, 2023. Braun—author of “From Heartbreak to Healing: The Reality of Teen Motherhood” and founder of the nonprofit She Is Incorporated—presented Annapolis City Council citations that were written and signed from Annapolis Mayor Gavin Buckley’s office. The women were presented with citations on behalf of She Is Incorporated during Braun’s first book signing, after sharing their testimonies about teen motherhood in her published project. Braun was a teen mother who supports other teen mothers through her nonprofit. Photo courtesy of She Is Incorporated (See more on page 9)

How to Find a Trustworthy Tax Preparer

Are you looking for a tax preparer for the upcoming season, but don't know where to find one you can trust?

There are many businesses – reputable or otherwise – that help people prepare and file their taxes each year. But some of these businesses aren't as reliable as they want you to believe. And a few might even be out to steal your refund.

Here are some key signs that suggest a tax preparer is one you should avoid:

1. They charge you a percentage of your refund.

Preparers that charge a percentage of your refund have an incentive to make your initial refund larger at first by claiming more credits and benefits than you really are entitled to. And when the IRS or Maryland Comptroller discovers this and begins an audit, you – not the preparer – are responsible for paying the IRS or Comptroller back. This results in a bigger payment for the preparer and extra debt for you.

In many cases, the percentage charged winds up being much more expensive than a normal flat rate charged by other preparers. This can be hundreds of dollars taken out of your refund that you could otherwise keep.

2. They don't have proper credentials.

A professional tax preparer should be a Certified Public Accountant (CPA), an Enrolled Agent (EA), an attorney, or registered as a tax preparer in the State of Maryland.

You can check to see if a preparer is a CPA on the Maryland Department of Labor's Certified Public Accountants

Public Query website. The IRS maintains a searchable list of every Enrolled Agent in the country. You also may request verification that someone is an EA directly from the IRS by following instructions on the IRS website.

Preparers without these credentials aren't qualified as a business to file other people's taxes. Often such preparers will use employees working off a template who do not understand enough about the law to avoid making potentially serious mistakes.

3. They offer refund anticipation loans.

Refund anticipation loans are notoriously bad deals that charge very high fees. You can avoid the fees and need for the anticipation loan by filing your taxes early.

4. They are only open for part of the year.

The least trustworthy tax preparers will appear during tax season, process as many returns as they can, and then

close up shop and move on. This leaves their customers without anyone to work with when the preparer's mistake or fraud leads the IRS or Comptroller into an audit of the customer's taxes.

For non-English speakers or limited-proficiency English speakers:

If you hire a tax preparer who speaks

your first language, be sure to have someone you trust verify that the paperwork that the preparer gives you in English actually states what the preparer claims it does. Unethical tax preparers may tell you one thing about a tax form, when in reality the form is very different. They also may say they completed a form correctly, but

actually didn't – taking advantage of your inability to read the full form.

So, where can I find a trustworthy tax preparer?

The Volunteer Income Tax Assistance Program (VITA) can provide free, high-quality tax preparation services to low- and moderate-income taxpayers through the Baltimore and Maryland CASH (Creating Assets, Savings and Hope) campaigns. The CASH Campaign of Maryland is now offering appointments for its IRS-certified, free tax preparation service. You may be eligible for this free program if you earned \$60,000 or less last year. Call 410-528-8006 or visit cashmd.org to learn more about the Baltimore and Maryland CASH campaigns.

You also can find other VITA free tax preparation sites nationwide at irs.treasury.gov/freetaxprep or by calling 800-906-9887.

AARP offers free tax preparation through its Volunteer Tax Aide Program to those over 50 years of age. Volunteers operate virtually or in-person nationwide and you don't need to be an AARP member to qualify. This program will open soon for the 2022 tax filing season. So, keep an eye out for more news.

If your taxes are relatively simple and you are comfortable completing online forms, you also may want to consider filing your own taxes online.



The IRS website at irs.gov/filing/free-file-do-your-federal-taxes-for-free has a list of IRS-partnered companies that offer free, guided federal tax filing programs that do much of the work for you. Keep in mind that each organization has a different set of criteria for eligibility and that state taxes may not be free. However, this is still a good option for those who are comfortable doing part of the work themselves.

This article was written by John Hardt, director of the Low Income Tax Clinic at the Maryland Volunteer Lawyers Service.



John Hardt
Courtesy photo

NOTICE

Any unsolicited manuscripts, editorial cartoons, etc., sent to **The Baltimore Times** become the property of **The Baltimore Times** and its Editorial Department, which reserves the right to accept or reject any or all such unsolicited material.

The Baltimore Times (USPS 5840) is published every Friday by **The Baltimore Times**, 2530 N. Charles Street, Suite 201, Baltimore, MD 21218. Subscriptions by mail \$60 per year. Standard bulk postage paid at Baltimore, MD 21233. Postmaster send address changes to: **The Baltimore Times** 2530 N. Charles St, Suite 201 Baltimore, MD 21218

CIAA MEN'S & WOMEN'S BASKETBALL TOURNAMENT

FEBRUARY 21-25 • CFG BANK ARENA IN BALTIMORE



THE NATION'S OLDEST HISTORICALLY BLACK ATHLETIC CONFERENCE



PLAN YOUR TRIP TO BALTIMORE
BALTIMORE.ORG/CIAA



Guest Editorials and Commentary

Keep Your Eyes Open Wide, America's Growing Surge of Violence is Worsening

Hot-tempered people used to engage in fistfights to settle beefs. Now, they just shoot. A new year has shown us that a shooter can be as young as six years old and as old as someone in their seventies.

How did America get here? CNN recently reported that in just three weeks, 39 mass shootings have occurred in America. Data was cited from the Gun Violence Archive. A mass shooting is defined as a single incident where four or more people are shot or killed, according to the FBI's definition.

On January 1, 2023, nine people were injured in Miami Gardens, Florida. A neighbor fired shots at a New Year's eve party, according to notes provided by the Gun Violence Archive. That was not the only incident on the first day of 2023.

Growing up is getting harder to do. Since we rang in the new year, the Gun Violence Archive also recorded that 100 twelve to seventeen year olds were killed; 21 zero to eleven year olds were killed; and 2,946 gun violence deaths occurred.

"Gun violence and crime incidents are collected/validated from 7,500 sources daily – Incident Reports and their source data are found at the gunviolencearchive.org website," per information provided by the Gun Violence Archive.

A city in California, Half Moon Bay, may have been unfamiliar to many until a news story broke at the top of the week. Seven people were reportedly killed there. Another victim was seriously wounded. The shootings occurred at two different locations, according to officials. CBS News reported that the San Mateo Sheriff's Office said that the suspect is in custody. Chunli Zhao, 66, "was located in his vehicle in the parking lot of the sheriff's substation, and a semi-automatic handgun was found in his vehicle, police said," per CBS. Zhao, a mushroom farmer, allegedly opened fire at two different mushroom businesses. He reportedly worked at one of them.

California was the site of another horrific scene.

"A 72-year-old man died by suicide after he allegedly killed 11 people in a mass shooting at a Monterey Park, California, dance studio on Saturday night," according to MSN's report.

And while episodes of violence are typically known to occur more in urban areas, violent episodes are piling up in beach front locations, sleepy towns, prestigious addresses and in cities. No age or race is immune.

Sadly, a 15-year-old was shot and killed in a Northwest Baltimore alley on Wednesday, January 25, 2023, according to Baltimore Police. But shooters are getting younger. Hours away from Baltimore, Abigail Zwerner, a 25-year-old teacher who worked at Richneck Elementary School, reportedly plans to join the school district in Newport News, Virginia, according to the AP. The teacher was left with serious injuries after a 6-year-old student shot her. Before the incident occurred, several school employees expressed concerns to school administrators who failed to act.

Metal detectors probably will not solve the problem of school shootings. Morality is fading. Violence is multiplying. America is broken, so keep your eyes open wide because everyone's safety is still at stake.

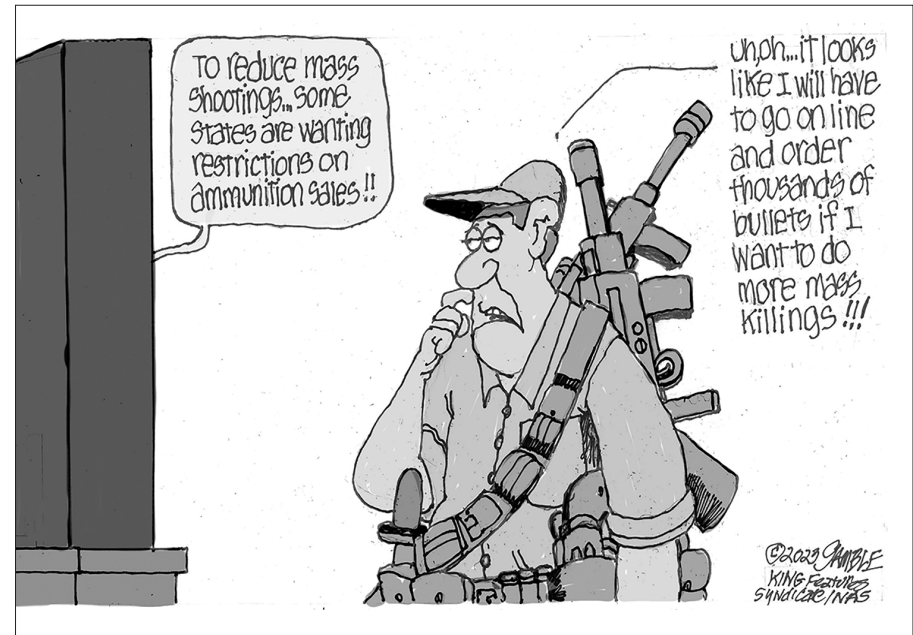

Community Affairs

Scholarship Submissions Accepted to Raise Awareness for Organ, Eye and Tissue Donation

Youth who want to use their voices for a good cause have a chance to make a difference through a creative scholarship opportunity. High school seniors are invited to apply for the Leslie A. Ebert Legacy of Life Scholarship that is being sponsored by Infinite Legacy.

Infinite Legacy is a nonprofit organ procurement organization serving people in Maryland, Northern Virginia and Washington, DC. The nonprofit facilitates organ, eye and tissue donation while also educating individuals about registering to be a donor.

According to information provided on Infinite Legacy's website, over 105,000 people are waiting for lifesaving transplants.

First place video and essay scholarship prizes are both \$5,000. Second place and honorable mentions will also be awarded. The purpose of the scholarship program is to raise awareness about registering to be an organ, eye and tissue donor. Video entries that educate others must be no longer than 90 seconds. At least two citations are needed for videos. Both essays and

videos must include calls to action. All essay and video entrants must currently be high school seniors. They must reside and attend high school, or be home-schooled, in Maryland, specific parts of Northern Virginia and the District of Columbia. Entrants must plan to attend a college, university or community college in the 2023 fall semester.

The essay submission deadline for essays and the entrant form is Friday, April 14, 2023, before 11:59 p.m. Qualified entrants must send essay entries to essayscholarship@infinitelegacy.org. Video entry forms must be emailed to videoscholarship@infinitelegacy.org and videos must be uploaded by Friday, April 14, 2023, before 11:59 p.m.

The email should state "LEGACY OF LIFE ESSAY SCHOLARSHIP" in the subject line. Please visit <https://www.infinitelegacy.org/get-involved/community-outreach/legacy-of-life-scholarship/> or <https://bit.ly/3iO1QGE> to learn more about applying for the Leslie A. Ebert Legacy of Life Scholarship.

Dr. Benjamin F. Chavis Jr. Named National Co-Chair of No Labels

By Stacy M. Brown
NNPA Newswire Senior
National Correspondent
@StacyBrownMedia

No Labels, a nonprofit think tank that describes itself as a national movement of Democrats, Republicans, and independents working to solve the country's most complex problems, has named Dr. Benjamin F. Chavis Jr. as its national co-chair.

The formal announcement occurred during a Zoom news conference on January 22.

It included welcome messages from Sens. Susan Collins (R-Maine), Joe Manchin (D-West Virginia), and former Maryland Republican Gov. Larry Hogan, among others.

Recording star Deborah Cox opened the introductory news conference by performing a spirited song about No Labels, who created the bipartisan House Problem Solvers Caucus and an allied Senate group that led passage of some of the most important legislation



Dr. Benjamin F. Chavis Jr., NNPA President and CEO

of recent years, including the CHIPS Act, a gun safety bill, and a rewrite of the Electoral Count Act in 2022.

Voiceovers were woven in of former U.S. Presidents from John F. Kennedy to Ronald Reagan and Barack Obama.

The organization then played a tribute video that included Dr. Chavis' family and his legendary career as a civil rights leader.

"As the new co-chair of No Labels, I'm proud to continue to be the president and CEO of the National Newspaper Publishers Association on the 196th anniversary of the Black Press of America," Dr. Chavis stated. "Working with former Sen. Joseph Lieberman and former Gov. Larry Hogan as co-chairs, I believe this will lift up the Black Press of America and elevate its visibility in the American mainstream politics, business, economics, and public policy that will affect the quality of life in the communities in which we serve."

Dr. Chavis continued:

"As a veteran of the civil rights movement, during the last six decades, I've learned a few things about the

importance of people working together across lines of race, ethnicity, language, geography, and the things that divide us. I want to work on things that unite us as Americans. I believe No Labels offers that opportunity but also that responsibility to move forward."

Lieberman, a former U.S. Senator from Connecticut, who changed parties in 2006 and is now an Independent, said No Labels is fortunate to have Dr. Chavis on board.

"Based on his history as a civil rights leader and the kind of person he is, I'm thrilled. Dr. Chavis has always been a bridge-builder and will bring civility, which is sorely needed in our government and our country," Lieberman asserted.

Hogan, who served two terms as Maryland governor, also congratulated Dr. Chavis.

"I'm thrilled to congratulate Dr. Chavis and welcome him to No Labels. I know Dr. Chavis will be a great addition to the leadership team of No Labels," Hogan stated.

"He shares our commitment to bringing people together to achieve common sense solutions for all Americans. Having worked with Dr. Martin Luther King Jr., Dr. Chavis knows what it means to fight for freedom and respect for all Americans, and that's exactly what No Labels stand for," Hogan concluded.

Manchin, the conservative-leaning Democrat, said he got involved with No Labels more than 12 years ago because the organization works to unite America.

"We're still working to unite this country," Manchin declared.

"What we've done in the last two years in a bipartisan way because of No Labels has been [major].

"So I'm thrilled to have the experience of Dr. Chavis and the wealth of knowledge he's gained over the years that he'll share with us to help make us a more perfect union."

In welcoming Dr. Chavis, Collins, Maine's longest-serving Senator, lent her voice. "As a highly respected civil rights leader, his service alongside Sen. Lieberman and Gov. Hogan will help move our organization and nation forward," Collins insisted.

"Dr. Chavis has dedicated his life to championing equality and encouraging our nation to live up to its ideals. He believes in American unity, democracy, and opportunity for all."

Dr. Chavis said his life's work had taught him that if everyone works together, divisions can be overcome.

"And when we overcome divisions, we make progress," he insisted.

"I believe we need to restore bipartisanship in the American Congress. We need to restore bipartisanship at the state legislative level.

"We need to restore bipartisanship at the local and municipal level. Americans today are worn out with all the divisions and looking for a way forward. No Labels offer that way forward."

The Annapolis Times

Publisher

Joy Bramble

Associate Publisher

Paris Brown

Editor

Dena Wane

Director of Special Projects

Dena Wane

Dir., Promotions/Entertain. Columnist

Unice Moseley

Administrative Assistant

Ida C. Neal

Writers

Ursula Battle

Andrea Blackstone

Stacy Brown

Demetrius Dillard

Rosa "Rambling Rose" Pryor

Website

James Collins

Layout

Chris Jones

The Baltimore Times is a publication of The Baltimore Times/Times of Baltimore, Inc. No part of this publication may be reproduced without the written consent of the publisher

Mailing Address

The Baltimore Times

2530 N. Charles Street, Suite 201

Baltimore, MD 21218

Phone: 410-366-3900- Fax 410-243-1627

www.baltimoretimes-online.com

Committed to the Cause

Tissue Recipient Educates, Leads to Help Save and Heal Lives

By Andrea Blackstone

Ieesha Johnson can relate to organ, eye and tissue donation from a first-hand perspective. In 2013, she fell during a competitive race and broke her hand. According to information provided on Infinite Legacy's website, the runner who tumbled down a hill headed to an emergency room for evaluation. After an X-ray was taken, the doctor informed her that a potentially cancerous tumor growing in her hand had caused the bone to crack when she fell. The growth needed to be removed. Although it turned out to be benign, Johnson needed donated tissue to heal her hand.

"The doctor said that the hole in the hand was so big. They would have to take bone out of my thigh, or I could get donor bone," Johnson said.

She opted to pursue the donor bone route. The bone transplant from a tissue donor was successful.

"So, I've been a tissue recipient for almost 10 years now," Johnson said.

Ironically, Johnson had been an organ donor since 2006. Her personal experience underscored the importance of signing up to become a registered organ donor.

Since graduating college, Johnson has worked in the healthcare field. She ultimately made a career of raising awareness about transplant donations. In 2001, Johnson visited an organ donor family event where donor family members were honoring their loved ones.

"It was just an overwhelming, emotional event. I was just filled with so much gratitude that people actually thought of others in their time of tragedy. So, I walked away and signed up to be an organ donor."

In 2007, Johnson began working in hospital services to ensure that nurses and doctors stayed educated about organ donation within their hospital systems. Johnson later began working in community outreach and public education.



Ieesha Johnson, director of community outreach at Infinite Legacy
Photo courtesy of Erin Bauer

"In 2016, I was promoted to manager and made that shift of doing a lot of outreach in our minority communities where the organ donation need is very high. Blacks are the highest on the waitlist for a kidney, but we're often the ones that say no to organ donation, due to the myths and misconceptions we may have heard over the years, so that's where my passion is working in a grassroots campaign," Johnson said.

She currently serves as the director of community outreach at Infinite Legacy. The nonprofit organ procurement organization's corporate office is in Baltimore, Maryland and the regional office is located in Falls Church, Virginia. It is formerly known as the Living Legacy Foundation of Maryland. Infinite Legacy merged with a sister organization called

Washington Regional Transplant Community in 2022. The organ procurement organization had served Northern Virginia, Washington, D.C. and the Maryland suburbs.

"We are passionate about giving life and restoring hope while honoring the legacy and generosity of donors and providing care to their families," Johnson said, explaining more about Infinite Legacy's mission. "We currently serve Northern Virginia, Washington, D.C., and the entire state of Maryland."

Johnson added that the merger provides increased opportunities to serve more donor families and improve transplant services. Her team handles the public education and outreach in the service areas. They work closely with high schools, public-facing organizations and volunteers.

"Our job is to help people understand the importance of organ, eye and tissue donation," Johnson added.

Johnson is a member of Donate Life America's advisory council. Donate Life America is a national nonprofit that increases donated organ, eye and tissue donations. Additionally, Johnson serves as a liaison to the Association for Multicultural Affairs in Transplantation. She is the president-elect who oversees the multicultural public education of 56 organ procurement organizations.

Infinite Legacy works closely with Donate Life Maryland (DLM) since DLM manages the state's organ, eye and tissue registry. Infinite Legacy also works very closely with transplant centers and donor hospitals.

"Donations can't happen without the three of us, so I like to call it a bridge. Infinite Legacy is in the middle, and then you have our donor families that are giving life, and then our transplant centers hold those patients to get a transplant," Johnson said.

John's initial call to action is simple. She wants more people to read information and stories about organ donation by visiting www.infinitelegacy.org. Johnson also recommends telling loved ones about end-of-life decisions.

"Have these conversations in your community, your homes and anywhere you congregate. That is the most important message that I want to send," Johnson said. "Also, too, it takes less than a minute to register to be an organ donor."

Visit www.infinitelegacy.org/get-involved/register-to-be-a-donor or www.donatelifemaryland.org to register.

You may contact Infinite Legacy to request someone to visit a local school, organization or business to talk to employees or students about organ, eye and tissue donation.

Ravens' Next Offensive Coordinator Must Showcase Lamar Jackson

By Tyler Hamilton

The Baltimore Ravens and offensive coordinator Greg Roman decided to part ways after six seasons together, three of which came with him being the offensive coordinator. Baltimore's offense was one of the NFL's best rushing attacks under Roman, as shown by their league-record 3,296 rushing yards in 2019.

"Greg devised and led our offense to no fewer than 26 historical NFL and franchise achievements. He established an identity for our offense. We are grateful for Greg's great work and abilities, and we wish him and his wonderful family the utmost happiness going forward," Harbaugh said in a statement.

Despite the success, it was time for a Roman to move on.

"After visiting with Coach [John] Harbaugh and after huddling with my family, I have decided that now is the right time to move on from the Ravens so that I can explore new challenges and opportunities," Roman said in a statement. "I'll truly miss Baltimore, but at the same time I am excited to attack my next opportunity with focus and passion."

Now the Ravens are searching for a new offensive mind to come in and find ways to put points on the board. Quarterback Lamar Jackson should be the focal point of their offensive coordinator search. Of course, that's provided he gets a contract worked out during the offseason, or at least has the franchise tag placed on him. It's obvious that Jackson is Baltimore's best offensive weapon. In fact, he's one of the league's most dynamic playmakers.

Jackson's MVP season in 2019 saw him lead the NFL with 36 passing touchdowns and only six interceptions. Not bad for a running back! Speaking of rushing, Jackson accumulated 1,206 rushing yards that season and followed up with 1,005 rushing yards the next year.



Lamar Jackson (left) and John Harbaugh (right)
Photo credit: Adam Hunger/AP Photos

There's this notion that Jackson can only operate in a run-heavy offense. That's not true.

"We were unique; we have a quarterback that can do everything – that's pretty unusual," Ravens coach John Harbaugh said.

A look back to Jackson's days at the University of Louisville gives a glimpse of what the next coordinator needs to do in Baltimore. In college, Jackson played under Bobby Petrino where they spread the field out and let Jackson go to work.

The Ravens have the personnel to operate in a spread offense. Rashad Bateman will be back from injury. Devin Duvernay is capable of being used on the perimeter and on a series of plays to get him the ball quickly and take advantage of his ability to make plays. Tylan Wallace and James Proche could serve as depth pieces if general manager Eric DeCosta decides to take a receiver like USC's Jordan Addison with the No. 22 pick in the 2023 NFL Draft. A trio of Addison, Duvernay and Bateman along with Mark Andrews at tight end would give Baltimore a potent

lineup. Add in J. K. Dobbins at running back and the result should be a pretty explosive offense.

Jackson has been criticized for his downfield passing outside the numbers. But his overall passing ability is much better than what has been shown under Roman. Former Ravens backup quarterback Robert Griffin III made an excellent point when he said Roman's offense is geared more towards running backs and tight ends. A lot of the passing concepts were less complex and limited options that Jackson had in the passing game. The focus was on finding ways to run the football. Just look at how the Ravens totaled the third-fewest passing yards (194.1) in the past three seasons as proof.

An emphasis needs to be placed on the quick passing game. Run more hitches, bubbles, sticks, slants, etc. Incorporate more run pass options as well. This quick attack will help relieve the offensive line if they are struggling to pass protect and will counter a blitzing defense as the quarterback will immediately get rid of the ball before feeling any pressure.

Ironically, those are two areas where the Ravens struggled over the years.

It wouldn't hurt to mix in some seam routes and other deep passing concepts like a skinny post from the slot receiver. Things open up more for the offense because Jackson demands attention from the defense. Most times a defender must be dedicated to spying on Jackson. More times than not, that's a mismatch on the open field. It also pulls one less defender out of pass coverage.

Getting a playcaller that understands how to showcase Jackson should be priority number one. That's where current Ravens wide receiver coach Tee Martin comes to mind. Having orchestrated a spread offense as a National Championship winning quarterback at the University of Tennessee, he can see the game through the same eyes as Jackson. He has offensive coordinator experience on his resume from his 2016 - 2018 tenure at USC. Martin has been with the Ravens since 2019 and would be an intriguing name to become the next offensive coordinator.

Freedom Way Exhibition Coming to Maryland Hall During Black History Month

By Andrea Blackstone

Bishop Craig Coates is a history buff and celebrant of Black history. The senior pastor at Fresh Start Church in Glen Burnie, Maryland is also a businessman who runs his flagship store called Craig Coates Couture. Growth Matters, LLC is Coates' company that provides community engagement focusing on black equity.

But Coates, who is also regarded as a historian, will now lead the Annapolis Juneteenth celebration that was envisioned by Phyllis Tee Adams in 2021. Juneteenth is traditionally celebrated on June 19. Union soldiers arrived in Galveston, Texas to inform people that the Civil War had ended. Enslaved people were finally free. Delivery of the news—in 1865—occurred two and a half years after President Lincoln's Emancipation Proclamation had already abolished slavery.

Coates incorporates his academic background that includes majoring in African American history at the University of Maryland, when he educates others about past truths.

"My school experience in history has allowed me to serve on many occasions as a lecturer at University of Maryland on the subject of Black history and wealth inequalities," Coates said.

Coates' reasons for delving into history are purpose driven. He reflected on his early years of pastoring around 1998.

"I had been pastoring for years, and I had started burying a lot of young men in the community. While on vacation, I had picked up some materials from Dr. Jawanza Kunjufu. He's out of Chicago, and he had written up a piece about the conspiracy to destroy African American males. After reading that, I decided I needed to go back to school, because prior to that, my degree was in apparel design," Coates said.



Bishop Craig Coates, creator of the "Freedom Way" exhibit
Photo courtesy of Bishop Craig Coates

Upon returning to school, Coates majored in African American studies. He felt like he did not know enough Black history. Coates also desired to assist Black males to figure out what was going wrong for them. During his new journey, a program was created at the Rapture Church in Annapolis. Coates pastored there for 14 years.

"It focused on everything from miseducation to the prison pipeline to the prison industry, to understanding our role as a man, where that went wrong and so many [other] things," Coates said.

Coates remains dedicated to teaching history in the community. In honor of Black History Month,

Maryland Hall will host a presentation of the exhibit called "Freedom Way: A Blueprint of African American Resistance and Liberation in the United States." It will be displayed in Maryland Hall's lower-level gallery from February 1-28, 2023, located at 801 Chase Street in Annapolis, Maryland. The music and art collection of framed graphic posters was created by Coates. A meet-the-artist reception will be held in the lower level of Bowen Theatre. Coates will provide a featured presentation on Sunday, February 19, 2023, at 1 p.m. The Freedom Way event is a precursor to the 2023 Juneteenth celebration.

The concept of Freedom Way began

when Adams informed Coates that she wanted a display at Annapolis' inaugural Juneteenth. Coates agreed to create an educational visual.

"I wanted to create something so big and so alive, and that's what we did. It took up almost half of the track with eight by four panels, telling our history from slavery to Juneteenth to forward to now, and that is how Freedom Way became. So many people visited Freedom Way at the first year's Juneteenth," Coates said.

He added that it is a blueprint of African American resistance and liberation from the documentation of the institutionalization of slavery in America to present. It includes documents from the Library of Congress and Coates' study material.

"I want people to realize that African American freedom has not come by way of it being given by the oppressor. As Dr. King says, 'It's common because the oppressed demanded it.' And still we do, and it always comes with bloodshed, unfortunately," Coates said. "People need to know, Black people, white people, Hispanic people, that liberation for Black people is still ongoing and still on the table."

Chris Haley, research director of the Legacy of Slavery in Maryland, remarked that images that were reflective of the journey for Maryland African Americans who sought freedom were provided by the Maryland State Archives for Freedom Way.

"I think Freedom Way is another good example of using an artistic approach to affect people emotionally about their history," Haley said.

All ages are invited to see "Freedom Way." Visit <https://www.marylandhall.org/events/freedom-way-exhibition-presentation/2023-02-19> for more information. Space is limited. Registration is required via <https://ticketing.marylandhall.org/28223/28224>.

Nonprofit Leader Reminds Teen Moms They Can Persevere, Pens Candid Book

By Andrea Blackstone

Prom is a social event that often marks a milestone in a young person's life. National Prom Day is now celebrated on March 31st of each year. PromGirl LLC, a retailer that is known for selling special occasion fashion, introduced the holiday. While proms are commonly attended by high school juniors and seniors with graduation in mind, some individuals such as Leanna Braun, did not have an opportunity to attend the momentous occasion, or participate in other adolescent traditions, because of balancing parental responsibilities at a young age.

"I was a fresh high school graduate two weeks prior to giving birth," Braun said, recalling a time when she balanced becoming a new mother and completing high school. "I had to recollect my thoughts in the sense of knowing that the little bit of time that I had left to enjoy being a teenager was coming to a slow end to a degree."

The 29-year-old Annapolis native who founded a nonprofit called She Is Incorporated in February 2020, reflected on giving birth to her first child at 17 years old.

Braun's responsibilities sunk in instantly when she gave birth to her son. According to Braun, even before she graduated from Annapolis Senior High School and became a young parent, she helped to raise some of her brothers and sisters. Their mother had a drug problem. She left when Braun was ten years old. Braun is her mother's oldest child.

"With an absent mom who was a mentally and emotionally sick drug abuser, I just overall experienced a lot of trauma. I was robbed of my childhood. A lot of my mother's pain was bleeding through me as the picker upper," Braun said.

Her stepfather was heartbroken that Braun became interested in boys when she was 14 years old. She thought a young boy filled a void in her heart.



Leanna Braun speaks at She Is Incorporated's first Teen Mom OG Brunch. Photos courtesy of She Is Incorporated

After Braun got pregnant by him, she disappointed some of her family members. Braun dealt with motherhood with limited support. She moved in with a brother and his wife. The change of address came with restrictions and real-world lessons.

When Braun reached the age of 19, she was a mother of two.

"I remember having my car repossessed and having no money to feed my children and crying to God to shelter me and my kids," Braun said, recalling the cycle of losing things she needed and regaining them.

She persevered beyond broken relationships and a host of challenges, including becoming homeless and needing resources. Braun did not stay down. She got her life together, secured another apartment, and asked God to help her serve a purpose. Braun is now employed by the City of Annapolis. She previously worked as a geriatric nursing assistant.

In 2020, Braun founded a nonprofit that supports teen mothers called She

Is Incorporated. She now provides a platform for teen mothers to have support.

"We teach them basic life skills, parenting techniques, we practice women empowerment, and we service that percentile of the community that's going through the emotions of parents, overall, just being a support system to them. Those young mothers realistically are ages 12 to 21," Braun said.

She added that older women who have been teen moms have been included. The nonprofit has expanded beyond Annapolis, but Braun's organization has also partnered with Annapolis Senior High School. More expansion is on the horizon.

Myeica Butler is a 33-year-old Annapolitan who had a child when she was 19. The mother of three, volunteers to help Braun with her nonprofit. She mentioned that young girls who are aware of Braun's experiences have been pointed in the right direction, since Braun has a network of women

who can support them. Butler said that Braun has provided help with mentoring, baby clothes, other baby items, backpacks, school supplies and other resources.

"She [Leanna] does a lot," Butler said. "She tries to be a support."

Braun recently published her first book entitled "From Heartbreak to Healing: The Reality of Teen Motherhood." Braun explained that the story is 100 percent true. Other teen mom testimonies were contributed by women she admires.

Braun mentioned that parents should give youth guidance at home before they leave the nest. In some households that do not consist of two parents, when support is lacking, youth may turn to friends or try to figure it out themselves.

"I couldn't be more thankful that I am the person that I am today to be able to tell my story openly," Braun said, mentioning her own self-healing. "I remember those moments of not being able to look at myself in the mirror and having so much doubt."

Visit www.sheisincorporated.org for more information about Braun and her book.



Leanna Braun, author and nonprofit founder

Legal Notice

NOTICE OF LIEN SALE

Notice is hereby given that a public auction will be held by competitive bid on www.storageauctions.net on 02/09/2023 at 11:00am to satisfy the lien on the property stored at Store Here Self Storage [Formerly Known As: Coastal Mini Storage] at 7120 Old Waterloo RD, Elkridge, MD 21075 in the units listed. Tenants may have notated the inventories listed at the time of rental. Landlord makes no representation or warranty that the units contain said inventories.

A0005=Adela Balan-Misc. Household Goods/Personal Effects. C0027=Anthony Oliver - Misc. Household Goods/Personal Effects. C0030=Tanya Taylor-Misc. Household Goods/Personal Effects. H0121=Joshua Costa-Misc. Household Goods/Personal Effects. J0186=Brian Shade-Misc. Household Goods/Personal Effects. L0234=Robert Fuentes-Misc. Household Goods/Personal Effects. N0305=Princess Cat El-Misc. Household Goods/Personal Effects.

All units must be paid for at the time of sale. Credit card payment accepted if transaction is over \$100. No checks accepted. No one under the age of 18 is allowed to attend the sale. Each person attending must agree to follow all Rules and Regulations of the sale. The landlord reserves the right to bid at the sale. All purchased goods are sold "as is" and must be removed by 5:00 p.m. on the day following the sale. Buyers must provide a current, original or a photocopy of their original resale permit at time of sale in lieu of sales tax. This sale is subject to cancellation in the event of settlement between landlord and obligated party.

Legal Notice

Looking for bricklayers who worked for the Bricklayers and Allied Craft (BAC) Union, Local 1 from 1966-1985. Please call (618) 973-2090. www.mrhfm.com

Leaf Filter
GUTTER PROTECTION

BEFORE LeafFilter
AFTER LeafFilter

BACKED BY A YEAR-ROUND CLOG-FREE GUARANTEE

EXCLUSIVE LIMITED TIME OFFER!
20% OFF + 10% OFF
YOUR ENTIRE PURCHASE SENIORS & MILITARY!
FINANCING THAT FITS YOUR BUDGET!
USA
Promo Code: 285
FREE GUTTER ALIGNMENT + FREE GUTTER CLEANING*

CALL US TODAY FOR A FREE ESTIMATE
1-844-566-3227
Mon-Thurs: 8am-11pm, Fri-Sat: 8am-5pm, Sun: 2pm-8pm EST

*For those who qualify. One coupon per household. No obligation estimate valid for 1 year. **Offer valid at time of estimate only. 2The leading consumer reporting agency conducted a 16 month outdoor test of gutter guards in 2010 and recognized LeafFilter as the #1 rated professionally installed gutter guard system in America. Manufactured in Plainwell, Michigan and processed at LMT Mercer Group in Ohio. See Representative for full warranty details. Registrations: 0366929922 CSLB# 1033795 Registrations# HIC 0649005 License# CBC056678 License# RCE-51604 Registrations# C172730 License# 550544 Suffolk HIC License# 52229-H License# 2102212986 License# 26200022 License# 262000403 License# 2106212946 License# MHIC 111225 Registrations# 176447 License# 423330 Registrations# IR731804 License# 50145 License# 408693 Registrations# 139V49953900 Registrations# H-19114 License# 218254 Registrations# PA09383 License# 41354 License# 7656 DORL #10783658-5501 License# 423330 License# 2705169445 License# LEAFFNW822JZ License# VV056912



We Cancel TIMESHARES for You

Every year 150,000 people reach out to us for help getting rid of their timeshare. In 2019, we relieved over \$50,000,000 in timeshare debt and maintenance fees. We can help.



Get your free information kit and see if you qualify:

888-984-2917

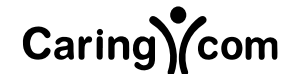

Caring.com's trusted Family Advisors help match seniors with the right senior living solution for their needs.

(877) 912-8092

dish Authorized Retailer

3-Year TV Price Guarantee

99% Signal Reliability, now backed by our Reliability Guarantee

Multi-Sport with NFL Redzone from NFL Network

A TV PRICE YOU CAN RELY ON
ONLY FROM DISH
3-YEAR TV PRICE GUARANTEE
A TV Price you can rely on - only from DISH

*Restrictions Apply
Call us now! 1-855-407-6870

ORDER TODAY & RECEIVE A \$100 GIFT CARD
GET DISH GET \$100
\$100 GIFT CARD
SEE US AT DISH STORE

DENTAL Insurance

from Physicians Mutual Insurance Company
Call to get your FREE Information Kit
1-855-337-5228
Dental50Plus.com/MDDC

Product not available in all states. Includes the Participating (in GA: Designated) Providers and Preventive Benefits Rider. Acceptance guaranteed for one insurance policy/certificate of this type. Contact us for complete details about this insurance solicitation. This specific offer is not available in CO, NY; call 1-800-969-4781 or respond for similar offer. Certificate C250A (ID: C250E; PA: C2500); Insurance Policy P150 (GA: P150GA; NY: P150NY; OK: P150OK; TN: P150TN). Rider kinds: B438, B439 (GA: B439B).

6208-0721

**CITY OF BALTIMORE
BUREAU OF WATER AND WASTEWATER
DEPARTMENT OF PUBLIC WORKS**

AMENDMENT TO RFI # 1385R - RESOURCE RECOVERY AT CITY OF BALTIMORE WASTEWATER TREATMENT FACILITIES

I. INTRODUCTION

The City of Baltimore (The City) owns and operates two wastewater treatment plants; the Back River Wastewater Treatment Plant (BRWWTP) (located at 8201 Eastern Ave, Baltimore, MD 21224) and the Patapsco Wastewater Treatment Plant (PWWTP) (located at 3501 Asiatic Ave, Baltimore, MD 21226). The City is envisioning transforming its existing wastewater treatment plants into resource recovery facilities. As part of this vision, the City is considering opportunities to harness the energy value, particularly of the biogas produced from anaerobic digestion at the BRWWTP, for on-site use or revenue generation through selling of either electricity or Renewable Natural Gas (RNG). The City is soliciting information from qualified firms specializing in handling and processing biogas to identify the best available and sustainable practices to recover energy from biogas as well as the best available procurement models to deliver the project.

At this point the City is focusing on resource recovery at BRWWTP since the plant already has anaerobic digestion. However, the City will also consider implementation of a resource recovery framework that incorporates PWWTP, either through a central facility or a separate facility at each plant.

II. BACKGROUND

The BRWWTP is designed for enhanced nutrient removal (ENR) with a design tertiary treatment capacity of 180 million gallons per day (MGD) and an average operating flow of 130 MGD. Primary sludge (PS), waste activated sludge (WAS), and tertiary sludge generated by the liquid train at the BRWWTP are thickened, further stabilized to Class B biosolids using two-stage acid-phase anaerobic digestion system, and finally dewatered to cake solids that are either composted or dried and pelletized. The biogas generated from the anaerobic digestion of sludge is currently flared.

The BRWWTP is equipped with a combined heat and power (CHP) generator facility, however, the CHP generator has been experiencing various mechanical issues and was taken offline for maintenance. The BRWWTP solids treatment processes are illustrated in Figure 1 and Figure 2.

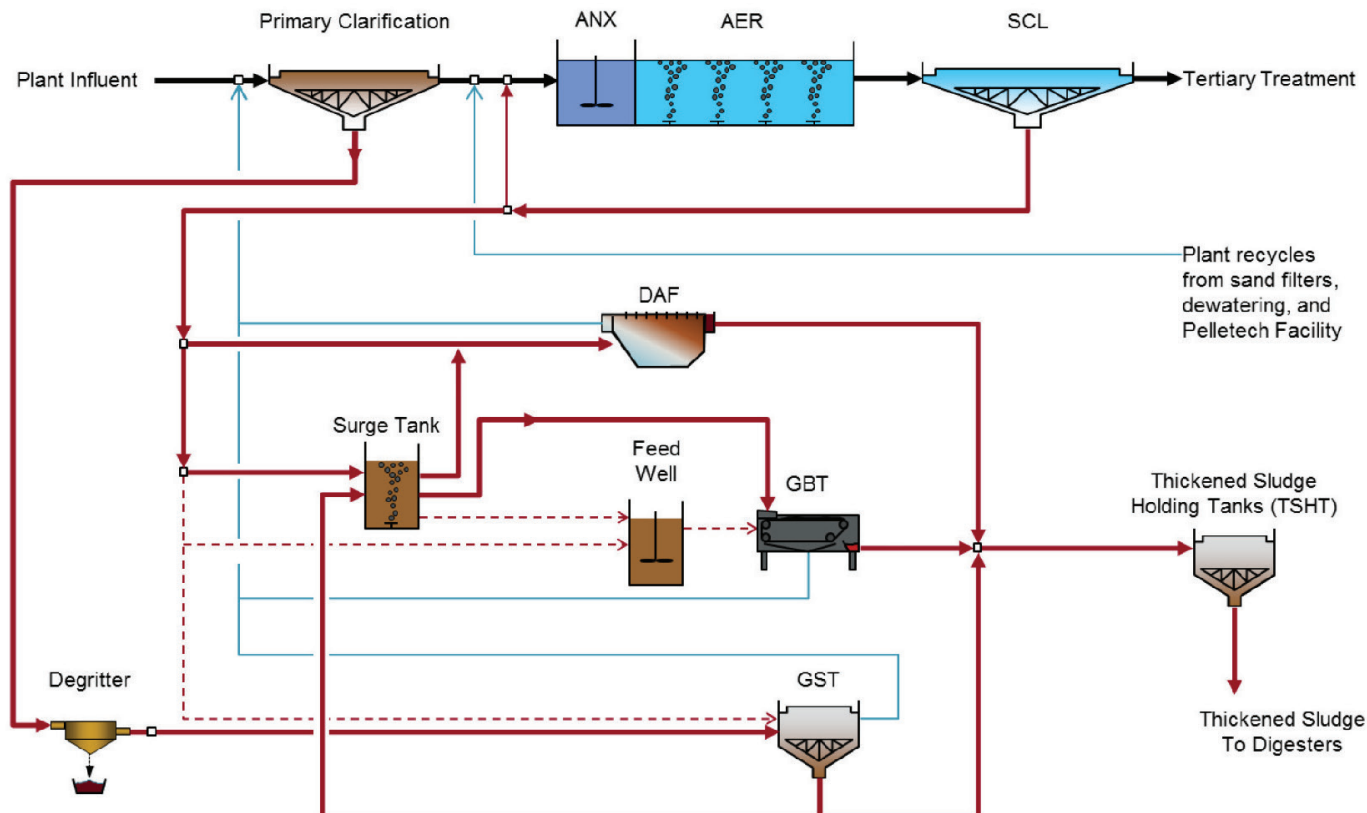

Figure 1 BRWWTP Solids Treatment Processes (Part 1 of 2)

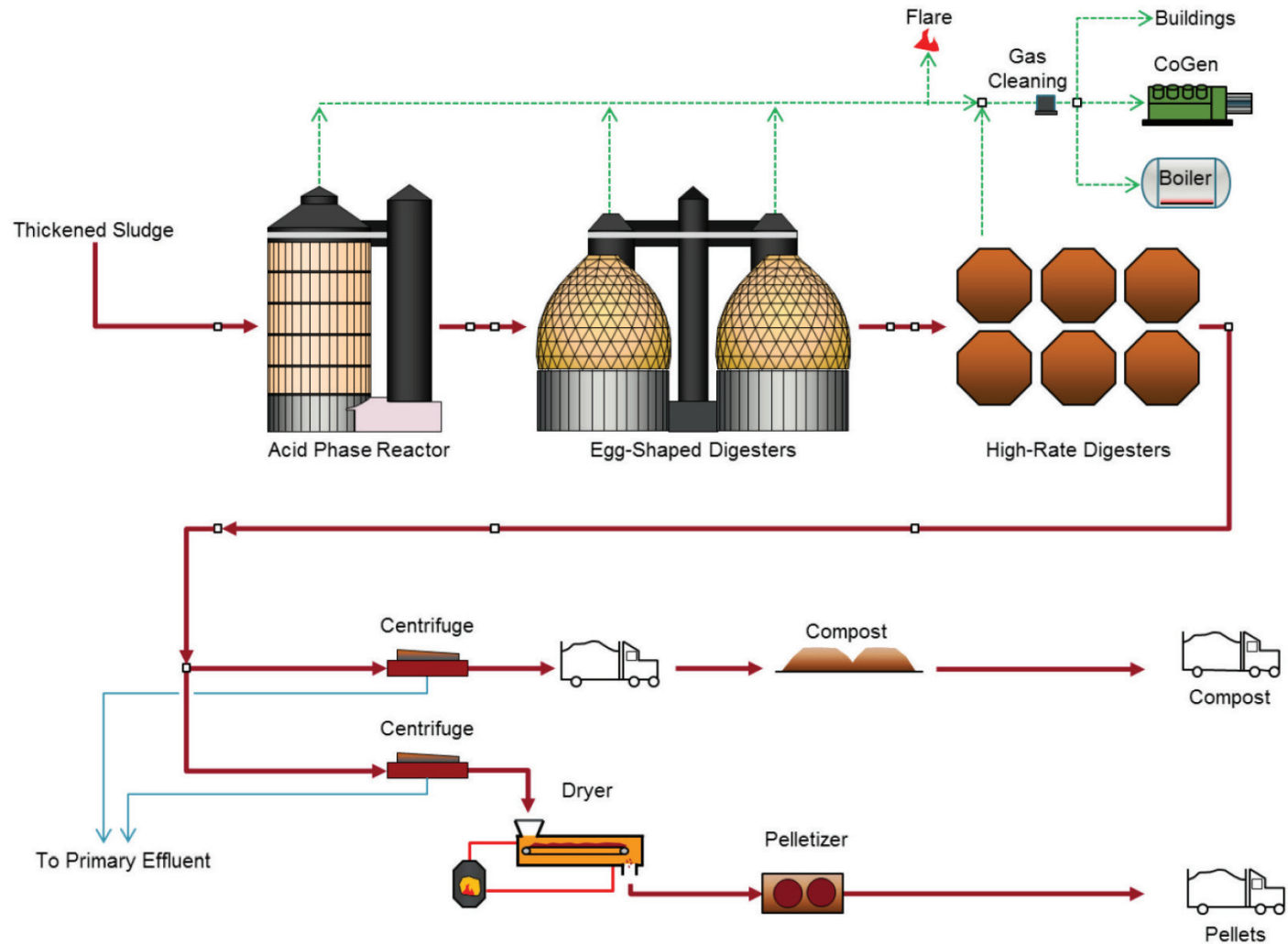

Figure 2 BRWWTP Solids Treatment Processes (Part 2 of 2)

Table 1 summarizes the historical quality of sludge that was transferred from Thickened Sludge Holding Tanks (TSHT) into the Acid-Phase Reactor (APR) during the period from 2018 through 2021.

Table 1 Historical Quality of Thickened Sludge at BRWWTP (2018-2021)

Sampling Point	Parameter	Unit	2018	2019	2020	2021
Thickened Sludge Holding Tank to Acid-Phase Reactor	Flow Avg	mgd	0.373	0.448	0.364	0.376
	Flow Max Month	mgd	0.432	0.528	0.408	0.485
	TS Avg		5.9%	5.3%	5.1%	5.7%
	TS Max Month		8.1%	5.8%	5.7%	6.1%
	TS Loading Avg	tons/day	93.3	99.4	78.9	89.0
	TS Loading Max Month	tons/day	130.2	115.3	92.5	122.3
	VS Avg		71.0%	78.0%	76.6%	74.2%
	VS Max Month		79.0%	80.2%	80.4%	80.0%
	VS Loading Avg	tons/day	64.6	77.7	61.3	66.1
	VS Loading Max Month	tons/day	84.2	91.4	72.4	87.4

Table 2 summarizes the historical quantities of biogas that was generated from the APR, Egg-Shaped Digesters (ESD), and HRD during the period from 2018 through 2021.

Table 2 Historical Quantities of Biogas at BRWWTP (2018-2021)

Sampling Point	Parameter	Unit	2018	2019	2020	2021
Biogas Flow	From APR Avg	KCFD	63	116	45	22
	From APR Max Month	KCFD	89	229	100	37
	From ESD Avg	KCFD	455	433	287	231
	From ESD Max Month	KCFD	725	577	521	422
	From HRD Avg	KCFD	1,017	977	800	965
	From HRD Max Month	KCFD	1,356	1,265	1,049	1,179

The PWWTP is designed for ENR with a design capacity of 73 MGD and an average operating flow of 63 MGD. It consists of preliminary treatment, primary treatment, secondary treatment, tertiary treatment, and hypochlorite disinfection to meet the final effluent criteria as per its NPDES Permit.

PS and WAS produced by the primary treatment and secondary treatment process are thickened on-site using gravity sludge thickeners and dissolved air flotation tanks. The thickened sludge is stored in a sludge blend tank and then conveyed to a Dryer (Pelletization) Facility that is owned and operated by a third-party vendor under a publicly procured long term lease/purchase agreement with the City since the early 1990s. There is no digestion process at the PWWTP.

Table 3 summarizes the historical quality of sludge that was transferred from Sludge Blending Tank (SBT) at PWWTP to the dryers during the period from 2018 through 2021.

Table 3 Historical Quality of Sludge at PWWTP (2018-2021)

Sampling Point	Parameter	Unit	2018	2019	2020	2021
Sludge Blending Tank to Dryer	Flow Avg	mgd	0.431	0.401	0.423	0.270
	Flow Max Month	mgd	0.746	0.505	0.582	0.382
	TS Avg		2.40%	2.52%	2.39%	2.80%
	TS Max Month		3.09%	3.08%	3.24%	3.23%
	TS Loading Avg	tons/day	41.92	41.95	42.08	31.54
	TS Loading Max Month	tons/day	59.53	66.67	60.62	44.27
	VS Avg		76.31%	78.98%	78.85%	79.20%
	VS Max Month		83.21%	82.01%	82.14%	83.13%
	VS Loading Avg	tons/day	33.68	33.81	34.32	25.84
	VS Loading Max Month	tons/day	48.00	53.92	49.71	35.04

III. SCOPE OF REQUESTED INFORMATION

The information the City is soliciting from qualified firms shall include, but is not limited to, the following:

1. Identification of up to three (3) optimized concept solutions to recover energy at the BRWWTP (or BRWWTP and PWWTP) that meet the following City priorities:
 - a. High efficiency
 - b. Minimal staffing requirements
 - c. Demonstrated local and/or national installations including:
 - i. Description of the facility including biogas cleaning/conditioning processes
 - ii. Date installed.
 - iii. Is the facility still in service?
 - iv. Successes and challenges.
 - v. References.

- d. Local and/or national service center and parts stock locations
- e. Short lead time requirements
- f. Future proofing/modularity/expandability to accept additional future loads
- g. Easy to operate and maintain

2. Identification of up to three (3) procurement project delivery models (such as DBO, DBFOM, DBOT, etc.) that minimize the duration, cost, and risk of the project. The City will be looking for partners to operate and maintain the proposed facilities. These models shall include various marketing strategies for selling or otherwise monetizing the generated renewable resources and/or revenue sharing arrangements or generate energy for local use. These models shall also include the expected agreement duration for each proposed delivery model.

3. Up to three (3) sample standard revenue sharing arrangements for marketing the generated renewable resources. This can be either generic or a redacted version of an existing agreement.

4. A general approach and corresponding scope of work of how the respondent is planning to generate, harvest, market or locally use the renewable resources. Include the apportionment of risks for unforeseen conditions inherent in the proposed approach.

5. Up to three (3) funding sources available to similar projects including the Inflation Reduction Act of 2022.

6. Projections for the estimated quantities of the renewable resource to be generated using the proposed approach, along with any conditions or prerequisites upon which the projection is based, and the corresponding estimate of revenue to the City.

7. A planning level (AACEI Class 5) life cycle cost analysis for each proposed solution. The respondent shall include anticipated capital cost, annual operating and maintenance costs, annual debt service costs, and annual revenue proceeds from marketing the generated renewable resource or energy cost savings for local use.

8. Concept level transitioning plan of assets back to the City at the end of the proposed agreement.

9. OPTIONAL: Respondents are encouraged to propose solutions to stabilize biosolids at the PWWTP and forecast renewable resources that can be recovered and marketed or locally used. The proposed solution could be combined with that proposed for BRWWTP or a separate facility at the PWWTP. If opted to do so, the respondent shall provide all relevant information listed in Section III-1 through III-8 of this RFI.

RESPONSE TO THE REQUEST FOR INFORMATION

1. Firms intending to submit a response to the request for information shall submit any relevant questions to Yosef Kebede, P.E. (EMAIL: Yosef.Kebede@baltimorecity.gov) and Hatim Fadlalla, P.E. (EMAIL: hatim.fadlalla@baltimorecity.gov).
2. The response to the request for information shall be submitted electronically to Yosef Kebede, P.E. (EMAIL: Yosef.Kebede@baltimorecity.gov) and Hatim Fadlalla, P.E. (EMAIL: hatim.fadlalla@baltimorecity.gov).
3. The response shall contain a contact person and associated contact information.
4. This amendment extends the response submission deadline to **12:00 P.M. (Noon) on March 03, 2023.** Submittals may not be accepted after this deadline.
5. The respondent shall submit their experience and history in performing this type of work, particularly those projects that have been successfully constructed, operated, and met prospective revenue goals. Include references of persons, firms, or agencies that the City may contact to verify the experience of the proponent.
6. The respondent shall submit electronically descriptive material in support of their response including articles, drawings, photographs, or other media that would be helpful in evaluating the response.
7. NOTE: The City will not be making an award based on responses to this RFI. Instead, information provided will be evaluated internally to determine the approach to resource recovery that best suits the City. If the City chooses to move forward with a resource recovery project, a separate RFP will be issued to solicit proposals.

PLAY

Responsibly

**There are lots of ways to celebrate,
but only one way to play... responsibly.**
For help, visit mdlottery.com/playresponsibly
or call 1-800-426-2537.

