

PRST STD  
 U.S. POSTAGE  
**PAID**  
 READING, PA - PERMIT 524

**HAMBURG**  
**King Frost Parade**  
 Saturday,  
 Oct. 29  
 at 7 pm  
 Sponsored by the  
 Hamburg Jaycees



**EAST PENN  
 VALLEY**



# Merchandiser

You can directly link to any display advertiser's website through our online edition. HIGHLIGHT & CLICK

Serving Eastern Berks & Western Lehigh Counties.  
 Weekly Circulation Over 40,481

PUBLISHED BY... THE WINDSOR PRESS, INC. (Family Owned & Independent Since 1958)  
 6 NORTH THIRD STREET, P.O. BOX 465, HAMBURG, PA 19526-0465 • FAX: 610.562.2770  
 610.562.2267 OR 1.800.562.5521 • Open Monday Through Friday 8 AM - 5 PM  
 ON THE WEB: www.windsorpress.com or www.epvmerchandiser.com.



WE ACCEPT

## OCTOBER 24-29

# LIQUIDATION SALE

# \$5 Million Inventory!\*

## 6 DAYS ONLY

**New Fords Up To \$10,000 Off!\***

**Preowned Vehicles Up To 60% Off!\***

**Payments From \$99 Month!\***

**No reasonable offer will be refused!\***

Hours: Mon. - Thurs. 8:30 am - 8:00 pm; Fri. 8:30 am - 6:00 pm; Sat. 8:30 am - 5:00 pm

**Brand New** 2016 Ford Focus



S, Auto. MSRP \$19,290

**0% APR x 60 Mo.**  
 Or Up To **\$4,000**  
 In Total Savings!\*

**Brand New** 2017 Ford Fusion



SE, Hybrid, Demo MSRP \$32,245

**0% APR x 60 Mo.**  
 Or Up To **\$5,000**  
 In Total Savings!\*

**Brand New** 2017 Ford Escape



SE, 4x4, Demo MSRP \$28,235

**0% APR x 60 Mo.**  
 Or Up To **\$5,000**  
 In Total Savings!\*

**Brand New** 2016 Ford F-150



Crew Cab, 4x4, Lariat Demo MSRP \$55,275

**0% APR x 72 Mo.**  
 Or Up To **\$10,000**  
 In Total Savings!\*

\*Taxes, title, license, and all legal PA State dealer documentation fees are extra. Liquidation definition from Dictionary.com: noun -- the process of converting commodities into cash. Ad does not indicate impending closure of business. Available inventory value as of 10/18/16. Up to amounts are before any on/off sticker discounts & include all rebates, and may require Ford Motor Credit Financing, which not all customers will qualify for. Focus #8618 1FGL331056, Fusion #8766 3FHR166083, Escape #8756 1FHUB25886, F-150 #8771 1FGFD09513. 0% APR financing for \$16.67 per \$1,000 financed for 60 months, or \$13.89 per \$1,000 financed for 72 months. Up to 60% off on 8522A 2012 Ford Focus original MSRP \$19,960, at \$7,995 with Ad and at \$99/mo. payment with \$2,000 down for 72 months for qualified buyers. Reasonable offers to be determined by dealer at time of write-up. Offers expire 10/29/2016 or while supplies last.

09/19-10/31

**FALL FESTIVAL!**

SPONSORED BY HALDEMAN FORD OF KUTZTOWN

Giant Corn Maze, Hay Ride Tours,  
 Pick-Your-Own Apple Orchard...  
 Family Fun For All!

Come to Haldeman and test drive a vehicle,  
 and you will receive a  
**FREE Family Four Pack** for this festival!\*

\*While supplies last. No purchase necessary. Event runs 09/19-10/31. Offer only at Haldeman Ford of Kutztown.

**THE BIG TIRE EVENT**

Buy 4 Select Tires, get up to

**\$140** IN MAIL-IN REBATES\* when you use the Ford Service Credit Card

Ford only. Prior purchases do not apply. Promotion runs from October 1 through December 31, 2016. \$70 Cash rebate on purchase of four tires from the above brands. Additional \$70 Rebate is for new or existing Ford Service and Quick Lane Credit Card holders when the entire purchase is on the card (cannot be combined with any other Ford Service Credit Card offers). Offer cannot be combined with any other dealership or manufacturer tire offers or specials. Qualifying tires must be purchased within one transaction. See Service Advisor for full details. Offer ends: 12/31/16.

**COUPON**

**PA State Inspection and Emission**

Includes Sticker & MCI Fee

**\$29.95**

\*Pass or fail. Does not include parts. Parts & Labor Additional. Most Cars & Light Trucks

Good only at Haldeman Ford.  
 Offer good through November 30, 2016

**COUPON**

**\$5000 Rebate By Mail**

When You Use The Ford Service Credit Card On Any Motorcraft Brake Service

Good only at Haldeman Ford.  
 Offer good through November 30, 2016



**HALDEMAN**

610-683-3553 KUTZTOWN

www.HaldemanFordKutztown.com

RT. 222, Next To Sittler Golf, Kutztown • Service: 610-683-3673

Service Hours: Mon. 7:30 a.m. to 8:00 p.m.,  
 Tues. - Fri. 7:30 a.m. to 5:00 p.m., Sat. 8 a.m. to 4 p.m.



# KRAUSE TOYOTA

## 2016 RAV4

**APR OFFER**



**0% APR** **60 MONTHS**

• Get 0% apr financing for 60 months on a new 2016 RAV4!

Offer ends 10-31-2016, cannot be combined and is subject to availability. On approved credit from Toyota Financial Services. 0.0% APR financing for 60 months with \$27.76 per \$1,000 borrowed. 0.0% APR financing for 48 months with \$20.33 per \$1,000 borrowed. 0.0% APR financing for 60 months with \$16.67 per \$1,000 borrowed. Annual Percentage Rate available to buyers with approved Tier 1+ through Tier 1 credit through Toyota Financial. Down payment may be required. Varies by region. Does not include College Grad or Military Rebate. Offer ends 10-31-2016. \*Covers normal factory scheduled service. Plan is 2 years or 25K miles, whichever comes first. The new Toyota vehicle cannot be part of a rental or commercial fleet, or a delivery or taxi vehicle. See plan for complete coverage details. Valid only in the continental United States and Alaska.

1.9% APR financing for 72 months with \$14.71 per \$1,000 borrowed.

## 2017 Camry

**APR OFFER**



**0% APR** **72 MONTHS**

+ \$500 TOYOTA FINANCE CASH

0% APR financing up to 72 months available to qualified buyers thru Toyota Financial Services. Total financed cannot exceed MSRP plus options, tax, title, license and dealer fees. 72 monthly payments of \$13.89 for each \$1,000 borrowed. Not all buyers will qualify. Buyers can receive a \$500 finance cash incentive from Toyota in addition to special APR financing if vehicle is purchased and financed through Toyota Financial Services. Incentive will be applied first to the down payment. One incentive per finance transaction. Finance incentive is available on approved credit to qualified customers through Toyota Financial Services. Not all buyers will qualify. Offer may not be combined with other offers unless specified otherwise. Dealer fees are extra. Vehicle shown may be prototype and/or shown with options. Actual model may vary. Vehicle must be taken from dealer stock and is subject to availability. Offers may not be combined with other offers unless specified otherwise. See participating Central Atlantic Toyota dealer for details. Dealer fees are extra. ToyotaCare covers normal factory scheduled maintenance for 2 years or 25,000 miles, whichever comes first. 24-hour roadside assistance is also included for 2 years and unlimited miles. The new vehicle cannot be part of a rental or commercial fleet, or a delivery/taxi vehicle. Roadside assistance does not include parts and fluids except emergency fuel delivery. Lease, APR and cash back offers may not be combined.

## 2016 Corolla

**APR OFFER**



**0% APR** **72 MONTHS**

• Get 0% apr financing for 72 months on a new 2016 Corolla!

0% APR financing up to 72 months available to qualified buyers thru Toyota Financial Services. Total financed cannot exceed MSRP plus options, tax, title, license and dealer fees. 72 monthly payments of \$13.89 for each \$1,000 borrowed. Not all buyers will qualify. Vehicle must be taken from dealer stock and is subject to availability. Offer may not be combined with other offers unless specified otherwise. See participating Central Atlantic Toyota dealer for details. Dealer fees are extra. ToyotaCare covers normal factory scheduled maintenance for 2 years or 25,000 miles, whichever comes first. 24-hour roadside assistance is also included for 2 years and unlimited miles. The new vehicle cannot be part of a rental or commercial fleet, or a delivery/taxi vehicle. Roadside assistance does not include parts and fluids, except emergency fuel delivery. Lease, APR and cash back offers may not be combined.

## 2016 Prius

**CASH OFFER**



**\$2,000 CASH BACK**

• Get \$2,000 cash back on new 2016 Prius from Toyota!  
Purchasers can receive \$2000 cash back from Toyota or can apply cash back to down payment. Vehicle must be taken from dealer stock by 10/31/16 and is subject to availability. Offer may not be combined with other offers unless specified otherwise. Dealer fees are extra. Vehicle shown may be prototype and/or shown with options. Actual model may vary. ToyotaCare covers normal factory scheduled maintenance for 2 years or 25,000 miles, whichever comes first. 24-hour roadside assistance is also included for 2 years and unlimited miles. The new vehicle cannot be part of a rental or commercial fleet, or a delivery/taxi vehicle. Roadside assistance does not include parts and fluids, except emergency fuel delivery. Lease APR and cash back offers may not be combined.

## PREOWNED VEHICLES

### '09 NISSAN CUBE

#19197A. **FUN TO DRIVE!!!** CLEAN CARFAX & HAD ONLY 1 OWNER!!! NICELY EQUIPPED WITH A AUTO. TRANS., AC, STEREO WITH A CD PLAYER, PWR. WIND & DOOR LOCKS & MUCH, MUCH MORE!!! NEW PA STATE INSPECTION & EMISSION STICKERS!!! BUY IN CONFIDENCE RIGHT HERE AT KRAUSE TOYOTA!!! BEST OF ALL...

**Only \$6,975**

### '10 TOYOTA YARIS 3-DR.

#19153A. **FUN-SPORTY-ECONOMICAL!!!** CLEAN CARFAX AND HAD ONLY 1 OWNER!!! RUNS AND LOOKS 100%, 4 CYL., 5 SPD., ICE COLD AIR CONDITIONING, STEREO WITH A CD PLAYER AND MUCH, MUCH MORE!!! NEW PA STATE INSPECTION AND EMISSION STICKERS!!! STATE INSPECTION INCLUDING 4 NEW TIRES MOUNTED AND BALANCED, 4-WHEEL ALIGNMENT, REAR BRAKES!!! BUY IN CONFIDENCE RIGHT HERE AT KRAUSE TOYOTA!!!

**\$6,975**

### '11 TOYOTA PRIUS II

#19809A. **ONE OWNER, COMPLETELY SERVICED AT KRAUSE!!!** CLEAN CARFAX & HAD ONLY 1 OWNER!!! IT WAS ALSO BOUGHT & COMPLETELY SERVICED AT KRAUSE TOYOTA FROM NEW!!! THE 30,000 SERVICE WAS DONE, AS WELL AS THE 60,000, 90,000 & THE 120,000 SERVICE WAS DONE RIGHT HERE AT KRAUSE TOYOTA!!! NICELY EQUIPPED WITH BLUE LOGIC, ALLOY WHEELS, STEREO WITH A CD PLAYER, PWR. WIND. & DOOR LOCKS & MUCH, MUCH MORE!!! NEW PA STATE INSPECTION AND EMISSION STICKERS!!! BUY IN CONFIDENCE RIGHT HERE AT KRAUSE TOYOTA!!!

**\$9,975**

### '12 KIA SOUL

#19741A. **FUN & SPORTY!!!** THIS CAR IS VERY NICELY EQUIPPED WITH AUTO. TRANS., AC, STEREO WITH A CD PLAYER, PWR. WIND. & DOOR LOCKS & MUCH, MUCH MORE!!! NEW PA STATE INSPECTION & EMISSION STICKERS!!! BUY IN CONFIDENCE RIGHT HERE AT KRAUSE TOYOTA!!!

**\$9,975**

### '07 BMW 328xi

#19720A. **JUST TRADED!!!** HAS A CLEAN CARFAX & HAD ONLY 2 OWNERS!!! VERY NICELY EQUIPPED WITH GPS NAVIGATION, HEATED LEATHER INT., PWR. MOONROOF, AUTO. TRANS. & MUCH, MUCH MORE!!! NEW PA STATE INSPECTION & EMISSION STICKERS!!! BUY IN CONFIDENCE RIGHT HERE AT KRAUSE TOYOTA!!!

**\$9,975**

### '08 SUBARU IMPREZA

#19216A. **ALL-WHEEL DRIVE UNDER \$10,000!!!** THIS CAR IS A 1-OWNER VEHICLE WITH ONLY 86,645 MILES!!! THAT'S AN AVERAGE OF LESS THAN 9,000 MILES PER YEAR!!! VERY NICELY EQUIPPED WITH AUTO. TRANS., AC, STEREO WITH A CD PLAYER, PWR. WIND. & DOOR LOCKS, AND MUCH, MUCH MORE!!! NEW PA STATE INSPECTION AND EMISSION STICKERS!!! BUY IN CONFIDENCE RIGHT HERE AT KRAUSE TOYOTA!!!

**\$9,975**

### '10 TOYOTA PRIUS IV

#19407A. **UP-TO-DATE SERVICING!!!** BEAUTIFUL! EQUIPPED WITH GPS NAVIGATION, JBL STEREO WITH A 4-CD PLAYER, ALLOY WHEELS, PWR. WIND. & DOOR LOCKS & MUCH, MUCH MORE!!! NEW PA STATE INSPECTION & EMISSION STICKERS!!! BUY IN CONFIDENCE RIGHT HERE AT KRAUSE TOYOTA!!!

**\$10,475**

### '08 MINI COOPER CLUBMAN

#19759A. **FUN TO DRIVE!!!** CLEAN CARFAX & HAD ONLY 1 OWNER, VERY NICELY EQUIPPED WITH A 6 SPD. MANUAL TRANS., AC, STEREO WITH A CD PLAYER, PWR. WIND & DOOR LOCKS, STAGE COACH REAR DOORS & MUCH, MUCH MORE!!! NEW PA STATE INSPECTION & EMISSION STICKERS!!! BUY IN CONFIDENCE RIGHT HERE AT KRAUSE TOYOTA!!!

**\$10,975**

### '11 HYUNDAI ELANTRA TOURING SE

#19316B. **HARD TO FIND! THIS ISN'T A BASE!!!** CLEAN CARFAX & ONLY 48,958 MILES!!! THAT'S LESS THAN 9,800 MILES PER YEAR!!! VERY NICELY EQUIPPED WITH A PWR. MOONROOF, LEATHER INT., ALLOY WHEELS, AT, AC, STEREO WITH A CD PLAYER, PWR. WIND. & DOOR LOCKS & MUCH, MUCH MORE!!! NEW PA STATE INSPECTION & EMISSION STICKERS!!! BUY IN CONFIDENCE RIGHT HERE AT KRAUSE TOYOTA!!!

**All For Only \$9,475**

### '15 HYUNDAI ACCENT GLS

#19422A. **ONLY \$11,700 FOR THIS CAR!!!** CLEAN CARFAX & HAD ONLY 1 LOCAL OWNER!!! WAS TRADED IN ON A 2016 TOYOTA RAV4 AWD. VERY NICELY EQUIPPED WITH AUTO. TRANS., AC, STEREO WITH A CD PLAYER, PWR. WIND. & DOOR LOCKS, TRACTION & STABILITY CONTROL, ABS BRAKES, KEYLESS ENTRY, SIRIUS SATELLITE RADIO, SIDE CURTAIN AIRBAGS & MUCH, MUCH MORE!!! NEW PA STATE INSPECTION & EMISSION STICKERS!!! BUY IN CONFIDENCE RIGHT HERE AT KRAUSE TOYOTA!!!

**\$11,700**

### '10 VW ROUTAN SE

#19679A. **BEAUTIFUL WITH MANY EXTRAS!!!** CLEAN CARFAX WITH VERY LOW MILES!!! ONLY 42,162 PERFECT MILES!!! THAT'S AN AVERAGE OF LESS THAN 7,100 MILES PER YEAR!!! EXTRAS INCLUDE HEATED LEATHER INTERIOR, REAR ENTERTAINMENT SYSTEM WITH A DVD PLAYER, PWR. SEATS, PWR. DOORS, ALLOY WHEELS., TOW PKG., PWR. WINDOWS & DOOR LOCKS & MUCH, MUCH MORE!!! NEW PA STATE INSPECTION & EMISSION STICKERS!!! BUY IN CONFIDENCE RIGHT HERE AT KRAUSE TOYOTA

**\$13,975**

### '12 LEXUS CT200H

#19159A. **WOW...IT'S A LEXUS HYBRID!!!** ONLY 1 OWNER!!! VERY NICELY EQUIPPED WITH HEATED LEATHER INT., PWR. MOONROOF, ALLOY WHEELS, AT, STEREO CD, PWR. WIND. & DOOR LOCKS & MUCH, MUCH MORE!!! NEW PA STATE INSPECTION & EMISSION STICKERS!!! BUY IN CONFIDENCE RIGHT HERE AT KRAUSE TOYOTA

**All For Only \$12,975**

### '12 TOYOTA RAV4

#19523B. **NOT A BASE RAV4!!!** ALL WHEEL DRIVE WITH EXTRAS!!! EQUIPPED WITH A PWR. TILT/SLIDE MOONROOF, 17" SPOKE ALLOY WHEELS, ROOF RACK, DAYTIME RUNNING LIGHTS, REAR PRIVACY GLASS, REAR CARGO TONNEAU COVER, BODY SIDE MOLDING, STEREO CD PLAYER, PWR. WIND & DOOR LOCKS & MUCH, MUCH MORE!!! NEW PA STATE INSPECTION & EMISSION STICKERS!!! BUY IN CONFIDENCE RIGHT HERE AT KRAUSE TOYOTA

**\$15,975**

### '14 DODGE RAM 1500 2WD REG. CAB

#19568A. **YES MA, IT HAS A HEMI!!!** GREAT FOR TOWING WITH THE 5.7 HEMI!!! CLEAN CARFAX & HAD ONLY 1 OWNER!!! VERY NICELY EQUIPPED WITH AUTO. TRANS., AC, SAT STEREO WITH A CD PLAYER, 20" ALLOY WHEELS, PWR. WIND. & DOOR LOCKS & MUCH, MUCH MORE!!! NEW PA STATE INSPECTION & EMISSION STICKERS!!! BUY IN CONFIDENCE RIGHT HERE AT KRAUSE TOYOTA!!!

**\$20,975**

### '08 TOYOTA TUNDRA CREW MAX SR5 4x4

#19524B. CLEAN CARFAX & HAD ONLY 1 OWNER. IT WAS ALSO BOUGHT & COMPLETELY SERVICED AT KRAUSE TOYOTA FROM NEW!!! OVER 25 SERVICE RECORDS AVAILABLE!!! MANY EXTRAS INCLUDING 5.7 V8, AT, STEREO W/A 6-CD CHANGER, PWR. WINDOWS & DOOR LOCKS, RUNNING BOARDS, PWR. SEAT, TOW PKG., ALLOY WHEELS. AND MUCH, MUCH MORE!!! NEW PA STATE INSPECTION & EMISSION STICKERS!!! BUY IN CONFIDENCE RIGHT HERE AT KRAUSE TOYOTA!!!

**\$20,975**

### '11 JEEP WRANGLER SAHARA UNLIMITED 4-DR!!!

#19697A. THIS JEEP DOES HAVE A CLEAN CARFAX!!! VERY NICELY EQUIPPED WITH A HARDTOP, AUTO. TRANS., AC, PWR. WINDOWS & DOOR LOCKS, ALLOY WHEELS., TOW PKG., STEREO WITH A CD PLAYER & MUCH, MUCH MORE!!! NEW PA STATE INSPECTION AND EMISSION STICKERS!!! BUY IN CONFIDENCE RIGHT HERE AT KRAUSE TOYOTA!!!

**\$27,975**

## TOYOTA CERTIFIED

### '14 TOYOTA COROLLA S PLUS

#19361A. CLEAN CARFAX & HAD ONLY 1 OWNER!!! IT WAS ALSO BOUGHT AT KRAUSE FROM NEW!!! TOYOTA CERTIFIED WARRANTY GOOD THRU DEC. 12, 2020 OR UP TO 100,000 MILES!!! VERY NICELY EQUIPPED WITH A BACKUP CAMERA, PADDLE SHIFTERS, ALLOY WHEELS, ENTUNE STEREO WITH A CD PLAYER & MUCH, MUCH MORE!!! BUY IN CONFIDENCE RIGHT HERE AT KRAUSE TOYOTA

**\$13,975**

### '13 TOYOTA CAMRY XLE

#19364A. **CLEAN CARFAX - LOCAL PA 1 OWNER!!!** BEAUTIFUL IN WHITE!!! TOYOTA CERTIFIED WARRANTY GOOD THRU JULY 19, 2020 OR UP TO 100,000 MILES!!! MANY EXTRAS INCLUDING A POWER MOONROOF, ALLOY WHEELS, STEREO WITH A CD PLAYER, POWER WIND. & DOOR LOCKS, & MUCH, MUCH MORE!!! BUY IN CONFIDENCE RIGHT HERE AT KRAUSE TOYOTA!!!

**\$15,975**

### '13 TOYOTA CAMRY LE

#P01349. **THAT'S RIGHT, ONLY 17,347 PERFECT MILES!!!** CLEAN CARFAX & HAD ONLY 1 OWNER!!! IT WAS ALSO BOUGHT & COMPLETELY SERVICED AT KRAUSE TOYOTA FROM NEW!!! ONLY 17,347 PERFECT CERTIFIED MILES!!! THAT'S AN AVERAGE OF LESS THAN 6,000 MILES PER YEAR!!! TOYOTA CERTIFIED WARRANTY GOOD THRU OCT. 29, 2020 OR UP TO 100,000 MILES!!!

**\$15,975**

### '15 TOYOTA COROLLA S+

#P01348. **LOW, LOW MILES!!!** CLEAN CARFAX & HAD ONLY 1 OWNER!!! IT WAS ALSO BOUGHT & COMPLETELY SERVICED AT KRAUSE TOYOTA FROM NEW!!! ONLY 14,320 PERFECT CERTIFIED MILES!!! THAT'S AN AVERAGE OF LESS THAN 7,200 MILES PER YEAR!!! TOYOTA CERTIFIED WARRANTY GOOD THRU NOV. 25, 2021 OR UP TO 100,000 MILES!!! VERY NICELY EQUIPPED WITH AUTO. TRANS., STEREO WITH A CD PLAYER, HEATED SEATS, ALLOY WHEELS, BACK-UP CAMERA, LED HEADLAMPS, FOG LIGHTS, REAR SPOILER, PWR. WIND. & DOOR LOCKS & MUCH, MUCH MORE!!! BUY IN CONFIDENCE RIGHT HERE AT KRAUSE TOYOTA!!!

**\$17,475**

### '13 TOYOTA SIENNA XLE

#19765A. **VERY CLEAN INSIDE AND OUT!!!** CLEAN CARFAX & HAD ONLY 1 OWNER!!! IT WAS ALSO BOUGHT & COMPLETELY SERVICED RIGHT HERE AT KRAUSE TOYOTA!!! VERY NICELY EQUIPPED WITH GPS NAVIGATION, BACK-UP CAMERA, PWR. MOONROOF, HEATED LTHR. INT., PWR. DOORS & PWR. LIFT GATE & MUCH, MUCH MORE!!! TOYOTA CERTIFIED WARRANTY GOOD THRU FEB. 27, 2020 OR UP TO 100,000 MILES!!! BUY IN CONFIDENCE RIGHT HERE AT KRAUSE TOYOTA!!!

**\$26,975**

### '12 TOYOTA RAV4 LIMITED 4x4

#19483A. **WHAT A BEAUTY!!!** THIS V6 WAS JUST TRADED IN HERE AT KRAUSE TOYOTA!!! IT HAS A CLEAN CARFAX & HAD ONLY 1 OWNER!!! IT WAS ALSO BOUGHT & COMPLETELY SERVICED RIGHT HERE AT KRAUSE TOYOTA!!! VERY NICELY EQUIPPED WITH A PWR. MOONROOF, HEATED LTHR. INT., TOW PKG., ALLOY WHEELS., 3M FILM ON HOOD, TUBE STEPS, ROOF RAILS WITH CROSS BARS, STEREO WITH A 6 CD PLAYER & MUCH, MUCH MORE!!! TOYOTA CERTIFIED WARRANTY GOOD THRU JUNE 27, 2019 OR UP TO 100,000 MI!!! BUY IN CONFIDENCE RIGHT HERE AT KRAUSE TOYOTA!!!

**\$29,975**

### '13 TOYOTA TUNDRA DOUBLE CAB 4x4

#19452A. **WHAT A BEAUTY!!!** CLEAN CARFAX & HAD ONLY 1 OWNER!!! IT WAS BOUGHT & COMPLETELY SERVICED RIGHT HERE AT KRAUSE TOYOTA FROM NEW!!! ONLY 18,270 PERFECT CERTIFIED MI!!! THAT'S AN AVERAGE OF LESS THAN 6,500 MILES PER YEAR!!! TOYOTA CERTIFIED WARRANTY GOOD THRU AUG. 16, 2020 OR UP TO 100,000 MILES!!! VERY NICELY EQUIPPED WITH A 4.6 LITER V8, AT, STEREO WITH A CD PLAYER, PWR. WIND. & DOOR LOCKS, BEDLINER, FOG LIGHTS, TUBE STEPS, TOW PKG., & MUCH, MUCH MORE!!! NEW PA STATE INSPECTION & EMISSION STICKERS WHICH INCLUDED NEW FRONT BRAKE PADS & ROTORS, MOUNTED & BALANCING A NEW TIRES, 4 WHL. ALIGNMENT, REPLACED WIPERS, ENGINE AIR FILTER, CABIN AIR FILTER, LUBE, OIL & FILTER!!! BUY IN CONFIDENCE RIGHT HERE AT KRAUSE TOYOTA!!!

**\$30,975**

### '10 TOYOTA 4RUNNER LTD 4x4

#19152A. **THIS IS THE ONE!!!** CLEAN CARFAX & HAD ONLY 1 OWNER!!! IT WAS ALSO BOUGHT & COMPLETELY SERVICED RIGHT HERE AT KRAUSE FROM NEW!!! VERY NICELY EQUIPPED WITH GPS NAV., PWR. MOONROOF, HEATED LTHR. INT., ALLOY WHEELS., SLIDING CARGO DECK, JBL STEREO WITH A 4-DISC CD PLAYER, PWR. WIND. & DOOR LOCKS & MUCH, MUCH MORE!!! TOYOTA CERTIFIED WARRANTY GOOD THRU MAY 15, 2017 OR UP TO 100,000 MI!!! BUY IN CONFIDENCE RIGHT HERE AT KRAUSE TOYOTA!!!

**\$28,975**

### '14 TOYOTA 4RUNNER LTD 4x4

#19714A. **WOW-WOW-WOW!!!** BEAUTIFUL CLEAN CARFAX & ONLY 1 OWNER!!! MANY EXTRAS INCLUDING GPS NAVIGATION, HEATED LEATHER INTERIOR WITH VENTED SEATS, RUNNING BOARDS, TOW PACKAGE, POWER MOONROOF, PARKING SENSORS, JBL STEREO WITH A CD PLAYER & MUCH, MUCH MORE!!! TOYOTA CERTIFIED WARRANTY GOOD THRU APRIL 1, 2021 OR UP TO 100,000 MILES!!! BUY IN CONFIDENCE RIGHT HERE AT KRAUSE TOYOTA!!!

**\$39,975**

The Longest Running Toyota Store In The Country...  
*Because of Customers Like You!*



**krausetoyota.com • 610.395.9858**

7702 Penn Dr., Breinigsville, PA 18031  
Just south off I-78 & Rt. 100S

# AMERICA'S OLDEST TOYOTA DEALERSHIP

**ARIENS**  
THE KING OF SNOW

**MOVE A TON IN NO TIME.**



AS LOW AS \$ **34**  
PATH PRO  
• HOUSING & PADDLE  
• COWL DESIGN

AS LOW AS \$ **34**  
COMPACT 24  
• AUGER  
• ENGINE

AS LOW AS \$ **67**  
DELUXE 28 SHO  
• AUTO-TURN™ STEERING  
• Reliable Ariens AX engine

**R.H. IORISH**  
MOWER SHOP LLC

Store Hours:  
Mon.-Thurs. 8 am-6 pm,  
Fri. 8 am-4 pm,  
Sat. 8 am-2 pm, Sun. Closed

3102 Woodside Rd., Alburtis (2 mi. above Huff's Church)  
**610-845-2164** **rhlorish.com**



**REAL ESTATE**

**FOR SALE: Lyons 4 Bedroom House: Includes 1 Bedroom apartment currently rented. 16 S Kemp St., \$195,000. Call 610-682-7837.**

**FOR SALE: Mobile Home 1974. New skirting, rug, tank, good condition, must be moved, it is a Skyline. Call 610-683-9271.**

**REAL ESTATE**

Land for sale: In Huff's Church Area. 3 plus acres, standard perk. Wooded. \$69,900. 610-967-3220.

**SPECTACULAR VIEW 5 Acre wooded lot in Rockland Township, Brandywine School District. \$85,900 possible owner financing. Call Monaghan Realtors at 610-683-5333.**

**Cheryl Sharayko**



**30 Years Experience Selling Real Estate**

Your Full-Time Realtor  
Serving Berks and Lehigh Counties  
Since 1986

**COLDWELL BANKER**

7 South Kemp Road, Kutztown • 610-683-3111  
Direct Line: 610-845-7534 • Cell: 610-763-8389  
E-mail: Cheryl.Sharayko@cbhomes.com

Thinking about making a move? Would you like to know how much your home is worth? Call today for a free market analysis.

**AFFORDABLE**



**WELL-MAINTAINED MODULAR** offering view of countryside. 4 nice-sized bedrooms, 2 full baths, family room with gas fireplace, eat-in kitchen, dining room and main level laundry. Nice sized deck for enjoying the outdoors. \$69,900

**JUST LISTED**



**BEAUTIFULLY MAINTAINED SINGLE** Totally renovated home featuring wood flooring in living room and dining room. Modern kitchen with tiled backsplash. Convenient main level laundry. 3 bedrooms and 1-1/2 baths. Covered front porch. Large back deck leads to nice sized yard with storage sheds. Daniel Boone School District. \$167,500

**NEW TO THE MARKET**



**SWISS CHALET** on 84 acres offering panoramic mountain views. 3 bedroom home featuring loft, living room with stone fireplace, dining area, rustic wood interior with wall of windows for gazing outdoors, detached 2-car garage. \$720,000

**PLENTY OF ROOM/TRANQUIL SETTING**

**A LOT OF HOME AT A GREAT LOCATION** Over 4,124 sq. ft., not including finished basement. Four bedrooms, family room with brick fireplace, eat-in kitchen features tile flooring and granite countertops, sunroom with wall of windows overlooking woodland and wildlife. Back deck runs length of home and overlooks fenced inground pool area with pool house. Master bath with whirlpool tub and separate shower. Stained woodwork, bay windows, built-ins, solid wood doors. All on 3 serene, partially wooded acres. \$379,900

"If you want a SOLD sign on your home, call me."

**PLEASE JOIN US IN CELEBRATION OF VETERANS DAY**

**KOSPIA FARMS**  
Saturday,  
November 5th  
10am - 5pm



- LIVE Remote with Bobby Gunther Walsh of Newsradio 790 WAEB 10 am - 2 pm
- Veterans Ceremony 12 pm - 1 pm
- All Day Live Music with The Angela Evans Duo and Nick Franclik and Friends
- Food Truck by Vince's Cheesesteaks
- Chili Contest (contact us to submit your best chili - no cost to enter)
- Wear your patriotic colors and we will award the best!
- Take part in our 'Hand-Painted' Flag!
- Pie-Eating Contest
- Silent Auction
- Marshmallow Roasting in our Fire Pits!
- Children's Booth
- USA-Made Flags for sale by American Fence and Flag

Welcoming all families and Veterans to join us for a great day benefiting our local Veterans and Boy Scouts. The ceremony will include a blessing, reading of names, singing of our National Anthem, and a Flag Retirement Ceremony. We will be assisted by our local Boy Scouts and the Brandywine School District. Drop off worn flags up until the day of the event and contact our farm via phone or email to submit a name to be read.

**Join us and spread the word!**



**liferis BETTER LOCAL** | **Kospia Farms**  
natural and creative living is our inspiration ... IT'S ALL THE BUZZ!

2288 State Street, Alburtis, PA 18011 - 610.682.7233 - www.kospiafarms.com

**REAL ESTATE**

**Own a Modular on Land! 575 Credit Score and Up! Discovery Homes at 484-641-5055. discoverymodularhomes.com**

**WATERFRONT LAND!** 5 acres - \$99,900. Unspoiled lake, next to State Land, just 3 hrs. NY City! Private wooded setting! Build, camp or invest! EZ terms. 888-738-6994 NewYorkLandandLakes.com (\*191934)

**REAL ESTATE**

**THINKING OF SELLING? Your Home, Business, Property or Land may be valued at considerably more than you might imagine. Call us for a free, no obligation Market Analysis. John W. Monaghan Group of Kutztown, Realtors, Inc. 610-683-5333.**

**LYON VALLEY GARAGE INC**  
Auto and Truck Repair

- PA Inspections
- PA Emissions
- General Repairs
- Detailing

Local Shuttle Service Available

**FREE T-SHIRT** w/Inspection/Emission  
While Supplies Last - With This Ad

**484-217-1000**

3843 PA Route 100, New Tripoli, PA 18066 Kerry Kehl, Owner



Manufactured in PA

**MATTRESSES**

Easy Roll  
**Shades**

**LOST CREEK FARM**

Clair Martin  
354 Oak Haven Rd.  
Fleetwood, PA  
610.683.7902

- Custom Sizes
- Fabric Options
- Long Life

**PUBLIC AUCTION**

**VILLAGE CENTER ZONED REAL ESTATE WITH 1450 SQ. FT. RESID. HOME & 4.8-ACRE LOT**  
Saturday, November 5, 2016 at 1:00 P.M.

**Location:** 6278 Route 309, New Tripoli, PA (very close to intersection of Rt. 309 & Rt. 100 - formerly occupied by a landscape business).  
See www.HouseAuctioneers.com for full ad/pics.

**Auctioneers: DOUG/TIM HOUSER, AU-000446L**  
**JASON/NATHAN HOUSER, Assoc. Aucts.**  
610-799-2396 or 570-386-2191

**Sale by: NEW TRIPOLI BANK**



**GET OUR SPECIALS ONLINE...SIGN UP FOR OUR WEEKLY EBLAST!**

We Set Up Our Circular Just Like Our Store So You Can

**SHOP FAST & SAVE MONEY**

OCTOBER 2016

SUN	MON	TUES	WED	THURS	FRI	SAT
23	24	25	26	27	28	29

This Week There are **7,469 Items On Sale!**

**Look For The Tags For 3 MONTHLONG Lockdown Pricing On Over 600 Items!**

**Hatfield Boneless Sirloin Chops**  
\$1.97/lb

**Quaker Maid Sandwich Steaks**  
21 oz  
\$4.97

**Locally Grown Huntsinger Farms White Potatoes**  
5 lb  
Buy 1 Get 1 FREE!

**Fresh Express Premium Romaine, Green & Crisp or Lettuce Trio**  
9-11 oz  
Buy 1 Get 1 FREE!

**Biery Cubed Mild Cheddar or Hot Pepper Cheese**  
2 lb  
\$9.97

**Biery Cubed Swiss Cheese**  
2 lb  
\$10.97

**6" Carrot Cream Cheese, Peanut Butter, Red Velvet, Apple Caramel or Pumpkin Cake Rolls**  
\$6.97

**Large Shrimp Ring**  
22 oz  
\$10.97

**Nabisco Chips Ahoy! Cookies**  
7-13 oz  
2/5

**Herr's Potato Chips**  
9.5 oz  
Buy 1 Get 1 FREE!

**Pepperidge Farm Milano Cookies**  
5.25-7.5 oz  
3/10

**Dole Fruit Bowls, Parfaits or Fruitcracy**  
4 pk  
2/5

**Act Advanced or Total Care Mouthwash**  
33.8 oz - Select Varieties  
\$4.97

**Suave Shampoo or Conditioner**  
30 oz - Select Varieties  
2/4

**Kraft Velveeta Cheese**  
16 oz  
\$3.97

**Cracker Barrel Cheese**  
8 oz  
2/7

**Jimmy Dean Breakfast Sandwiches**  
8 ct  
\$8.47

**Kellogg's Eggo Pancakes, French Toast Sticks or Waffles**  
9.8-16.4 oz  
2/5

**THIS WEEK'S SPECIAL EVENTS**  
Available on Tuesday, October 25th Between 11 a.m. & 2 p.m.  
Berks Hot or Mild Smoked Sausage Sandwich - 2/\$3

GOOD ONLY AT BOYER'S EXPIRES 10/29/2016

**Kraft Mayonnaise**  
(30 oz)  
\$2.97  
Limit 2 with \$25 purchase \$3.97 without coupon  
PLU #803  
Coupon good at Boyer's Food Market only. Limit two per customer per shopping visit. Coupon in effect 10/23/16-10/29/16.

GOOD ONLY AT BOYER'S EXPIRES 10/29/2016

**Maxwell House Coffee**  
(29.3-30.6 oz)  
\$6.97  
Limit 2 with \$25 purchase \$8.97 without coupon  
PLU #733  
Coupon good at Boyer's Food Market only. Limit two per customer per shopping visit. Coupon in effect 10/23/16-10/29/16.

GOOD ONLY AT BOYER'S EXPIRES 10/29/2016

**Essential Everyday Macaroni & Cheese**  
(7.25 oz)  
4/\$1  
Limit 2 with \$25 purchase 4/\$2 without coupon  
PLU #882  
MUST BUY 4!  
Coupon good at Boyer's Food Market only. Limit two per customer per shopping visit. Coupon in effect 10/23/16-10/29/16.

GOOD ONLY AT BOYER'S EXPIRES 10/29/2016

**Frito Lay Doritos**  
(9.5-11.5 oz)  
\$1.97  
Limit 2 with \$25 purchase 2/\$5 without coupon  
PLU #877  
Coupon good at Boyer's Food Market only. Limit two per customer per shopping visit. Coupon in effect 10/23/16-10/29/16.

GOOD ONLY AT BOYER'S EXPIRES 10/29/2016

**Tombstone Pizza**  
(20-22.1 oz)  
\$2.47  
Limit 2 with \$25 purchase 3/\$10 without coupon  
PLU #881  
Coupon good at Boyer's Food Market only. Limit two per customer per shopping visit. Coupon in effect 10/23/16-10/29/16.

GOOD ONLY AT BOYER'S EXPIRES 10/29/2016

**FREE 2 Liter Crush Soda when you buy 3 Pepsi 12 pk/12 oz cans at 3/\$12 (Up to \$1.67 value)**  
PLU #852  
Coupon good at Boyer's Food Market only. Limit two per customer per shopping visit. Coupon in effect 10/23/16-10/29/16.

**Hatfield Center Cut Boneless Pork Chops**  
Big Value Pack  
\$2.97/lb  
Lesser Quantities \$3.97/lb

**Hatfield Whole Boneless Pork Loin**  
\$1.97/lb

**73% Lean Ground Beef**  
\$1.97/lb

**Top Round London Broil or Roast**  
\$2.97/lb

**Bagged Apples**  
3 lb - Gala, McIntosh, Red Delicious or Ginger Gold  
\$1.97

**Zeigler's Apple Cider**  
64 oz  
\$1.97

**Hobgoblin Red, White or Black Seedless Grapes**  
\$1.97/lb

**HALLOWEEN PARTY SALE**

**A-Treat Soda**  
6 pk/12 oz cans  
2/\$4

**Kool-Aid Jammers**  
10 pk  
2/\$5

**Capri Sun**  
10 pk  
2/\$5

**Nestle Pure Life Water**  
24 pk/16.9 oz btls  
2/\$5

**Bachman Jax**  
9.75 oz  
2/\$4

**Milky Way, 3 Musketeers or Snickers Fun Size**  
9.9-12 oz  
2/\$6

**Blue Diamond Almonds**  
14-16 oz  
\$7.97

**Nabisco Snack Crackers**  
3.5-9.1 oz  
4/\$10

**Green Giant Vegetables**  
14.5 oz Green Beans, 14.75 oz Cream Style Corn, 15 oz Sweet Peas or 15.25 Whole Kernel Corn  
5/\$3

**Charmin Essentials Strong or Soft Bath Tissue**  
12 giant rolls  
\$4.97

**Bounty Basic Full Sheet Paper Towels**  
8rl  
\$4.97

**Xtra Liquid Laundry Detergent**  
75 oz  
\$1.97

**Swiss Premium Teas or Drinks**  
Gallon  
2/\$4

**Nestle Toll House Cookie Dough**  
16-16.5 oz  
2/\$5

**Land O'Lakes Spread Butter with Canola Oil**  
15 oz  
2/\$7

**Crystal Farms Butter**  
16 oz  
2/\$7

**Heluva Good Sour Cream**  
16 oz  
3/\$5

**Pepperidge Farm Layer Cakes**  
19-19.6 oz  
3/\$6

**Stouffer's Family Size Entrees**  
31-40 oz  
\$5.97

**Auntie Anne's Pretzels**  
4.5-13.4 oz  
2/\$6

**Ore-Ida Potatoes or Onion Rings**  
16-32 oz  
2/\$6

**Freschetta Canadian, Self Rising or Artisan Pizzas**  
18.5-28.15 oz  
2/\$11

**Keekler Club Crackers or Sticks**  
11-13.7 oz  
Buy 1 Get 1 FREE!

**Entenmann's Harvest Items**  
8.25-18 oz  
Buy 1 Get 1 FREE!

**Orville Redenbacher's Microwavable Popcorn**  
3 pk  
Buy 1 Get 1 FREE!

**Bickel's Potato Chips**  
8.5-9 oz  
Buy 1 Get 1 FREE!

**Herr's Tortilla Chips**  
10-13 oz  
Buy 1 Get 1 FREE!

**Oberto Meat Snacks**  
2.5-3.25 oz  
Buy 1 Get 1 FREE!

**Betty Crocker or Mott's Fruit Snacks**  
4.5-8 oz  
Buy 1 Get 1 FREE!

**Heluva Good Bar or Shredded Cheese**  
8 oz  
Buy 1 Get 1 FREE!

**Heluva Good Dips**  
12 oz  
Buy 1 Get 1 FREE!

**Mama Rosie's Ravioli or Gnocchi**  
12-14 oz  
Buy 1 Get 1 FREE!

**Soup Season Is Here!**

**Campbell's Condensed Soups**  
10.5-10.75 oz  
4/\$5

**Campbell's Chunky or Healthy Request Soup**  
15.2-19 oz  
Buy 1 Get 1 FREE!

**Campbell's Bowl Soup**  
15.4 oz  
4/\$5

**Campbell's Soup At Hand**  
10.75-11.1 oz  
4/\$5

**DELI PARTY FAVORITES**

**Tyson Boneless BBQ or Buffalo Chicken Wings**  
Hot or Cold Grab and Go  
\$4.97/lb

**Tyson Wing Stingers**  
Hot Bar or Grab and Go  
\$4.99/lb

**21" Hoagies**  
\$8.97

**Hatfield Cooked Ham**  
\$3.97/lb

**Mrs B's White American Cheese**  
\$3.97/lb

**Eckrich Hard Salami**  
\$4.97/lb

**Cucina Grande Cheese Pizza**  
30 oz  
\$6.97

**Cucina Grande Pepperoni or Meat Mania Pizza**  
29.5-32.5 oz  
\$7.47

**\$10 OFF ANY PARTY TRAY/CATERING ORDER FROM OUR DELI OR BAKERY OF \$50.00 OR MORE**

Coupon good at Boyer's Food Market only. Limit one per customer per shopping visit. Coupon in effect 10/23/16-10/29/16. PLU#726

## CONSIGNMENT SALE



209 Oakhaven Rd.  
Fleetwood, PA 19522  
PH: 610-683-7161  
FAX: 610-683-5429

**PRODUCE AUCTION, INC.**  
www.kutztownproduceauction.com

**Saturday, November 5, 2016**

**Partial Sale:** Pecway gooseneck 20 ft. flatbed, landscaping material, stone pavers, furn., household items, clothing, housewares, shop items, lots of misc. sale items, more at day of the sale. Hay, straw & grain will also be sold Saturday.  
**George Frey, AU302L**

## For Sale

### Small Hydraulic Cylinder & Hydraulic Jack & Fab. Repair Shop

All tools, parts, equipment, hyd. hose, mach. hoses, fittings.  
Does not include building.  
**610-921-0591**

### FARM EQUIPMENT/ LIVESTOCK

**FOR SALE:** 2 Nanny goats, 8 months old bred \$125 each; call 610-562-3761.

**Piglets for sale:** \$55; 610-987-6256.

### FARM EQUIPMENT/ LIVESTOCK

**Fill Your Freezer with Quality Grass fed Black Angus Beef, approx. 1200 lbs. Each. \$1.25 per pound, live weight. Processing available. Call for details. Also grain fed Angus Beef Available Berks Co. Call 610-683-5204.**

## CASH FOR YOUR CAR

ANY MAKE, ANY MODEL CARS, TRUCKS, SUVS  
CALL OR STOP IN TODAY - ASK FOR BRIAN  
Specializing in Quality Prowned Vehicles & Auto Repair!

2001 DODGE DAKOTA QUAD CAB V8, 4X4, 105K .....\$7,495  
1998 DODGE DAKOTA CLUB CAB V6, 4X4, 78K.....\$6,995  
2000 JEEP WRANGLER 6 Cyl., 5 Spd., Hardtop, 98K .....\$7,495

## NOTHSTEIN MOTORS

610-395-2054  
1111 S. Route 100, Trexlertown, PA 18087

# TRUMP STILL TELLS THE TRUTH!

## But Washington, Wall Street & "Hollyweird" Still Can't Handle The Truth???

Sponsored By a Deplorable To MAKE AMERICA GREAT AGAIN.  
Sponsored By An Irredeemable Deplorable For The Truth.

### AUCTION LISTINGS

<p>10-25-16 Bally Fire Co., 537 Chestnut St. 10-26-16 Leesport Farmers Mkt. Auction Gallery 10-27-16 105 Lobachville Rd. Fleetwood 10-27-16 Fogelsville Auc. Ctr., 820 Nursery St. 10-28-16 144 N. Whiteoak St., Kutztown 10-28-16 Saucony Hall, 85 Industrial Ave., Kutztown 10-28-16 6648 Milo Rd., New Tripoli 10-29-16 7661 Carls Hill Rd., Zionsville 10-29-16 Renningers, 740 Noble St., Kutztown 10-29-16 80 Kepner Rd., New Ringgold 10-29-16 7661 Carls Hill Rd., Zionsville 10-30-16 Andreas Station House, 42 Andreas Rd. 10-30-16 144 N. Whiteoak St., Kutztown 10-31-16 91A Bower Rd., Reading 10-31-16 Leesport Farmers Mkt. Banquet Hall 10-31-16 382 Long Lane, Walnutport 11-02-16 ONLINE ONLY - 630 Municipal Dr., Nazareth 11-03-16 Oley Valley Auc. Ctr., Rts. 73, 662 &amp; Oley Rd. 11-05-16 6278 Route 309, Walnutport 11-05-16 1113 E. Emmaus Ave., Allentown 11-05-16 209 Oakhaven Rd., Fleetwood 11-05-16 22 Coal St., Middleport, Sch. Co. 11-05-16 5212 Schochary Rd., New Tripoli 11-07-16 Leesport Farmers Mkt. Ctr. Ct. Meeting Rm. 11-09-16 Leesport Farmers Mkt. Auction Gallery 11-12-16 357 Zions Church Rd., Shoemakersville 11-13-16 946 Clauss Rd., Lenhartsville 11-16-16 Leesport Farmers Mkt. Auction Gallery 11-17-16 Oley Valley Auc. Ctr., Rts. 73, 662 &amp; Oley Rd. 11-19-16 Exeter Township 11-25-16 144 N. Whiteoak St., Kutztown 11-25-16 4550 Old Packhouse Rd., Schnecksville, Fire House Pavilion 11-26-16 60 Delcamp Rd., Fleetwood 12-01-16 Leesport Farmers Mkt. Auction Gallery 12-03-16 Beltzner Hall, Kutztown Fairgrounds 12-05-16 Leesport Farmers Mkt. Banquet Hall 12-14-16 Leesport Farmers Mkt. Auction Gallery 12-15-16 Oley Valley Auc. Ctr., Rts. 73, 662 &amp; Oley Rd. 12-16-16 144 N. Whiteoak St., Kutztown 12-28-16 Leesport Farmers Mkt. Auction Gallery 01-01-17 Oley Valley Auc. Ctr., Rts. 73, 662 &amp; Oley Rd.</p>	<p>T. Lorah Diefenderfer Auc. Co. G. Miller IV Zettlemoyer Auc. Co. D. Loeb C. Shirck Tim Weaver Auc. Serv. R. Clinton &amp; Co. D.J. Consignment Auc. D. &amp; T. Houser Somers Auctioneering D. Arner D. Loeb Diefenderfer Auc. Co. Wagner Auc. Serv. Wagner Auc. Serv. D. Arner J. Hall Auctions J. Haas D. &amp; T. Houser R. Clinton &amp; Co. Kutztown Produce Auc. K. Leiby, B. Gelsinger C. Shirck K. Leiby, B. Gelsinger Diefenderfer Auc. Co. Wagner Auc. Serv. Wagner Auc. Serv. Diefenderfer Auc. Co. J. Haas K. Leiby, B. Gelsinger D. Loeb Wagner Auction Service G. Miller IV Diefenderfer Auc. Co. J. Haas G. Miller IV K. Leiby, B. Gelsinger Diefenderfer Auc. Co. J. Haas D. Loeb Diefenderfer Auc. Co. J. Haas</p>
--	--

THE ABOVE AUCTIONS ARE CURRENTLY SCHEDULED TO APPEAR IN THE EAST PENN VALLEY AND/OR NORTHERN BERKS MERCHANDISER.  
This listing published courtesy of The Windsor Press, Inc., Hamburg, PA



# JOHN MONAGHAN

- GROUP OF KUTZTOWN - REALTORS

154 WEST MAIN ST., KUTZTOWN, PA      LOCALLY OWNED & OPERATED      610-683-5333

### RELAXING RETREAT



Like being on vacation year round! This nearly 4-acre property offers expansive deck w/hot tub, wedding garden area, pond w/fountain, 2 storage sheds & greenhouse. Inside boasts a lg. kitchen w/so many features! Private 2nd floor w/master BR, full BA, office/loft. L/L fam. rm. 3-car gar.  
Brandywine Schools.  
ID# 6862449

**\$307,000**

### GET NOTICED!



Professional office located on Route 222, free-standing, approx. 2000 sq. ft. Ideal for medical, legal, service based offices. Plenty of parking. Major exposure.  
ID# 6471742

**\$179,500**

### QUAINT LOCATION



Great starter home in the town of Kempton! This 3-BR, 1 1/2-BA single home has a large bright kitchen which has been freshly painted, expanded attic w/electric & heat. Fenced-in yard. Detached 1-car garage w/workshop & 2nd floor.  
ID# 6831811

**\$109,900**

KUTZTOWN - This panoramic view is spectacular! Beautiful 34 +/- ac. lot in the Boro. of Kutztown w/the mdrn. bonus of connecting to public water & sewer. Walking distance to Kutztown conveniences yet easily accessible to I78 to head to major cities. .... \$275,000 ID# 6530984  
KUTZTOWN - Wow, 4 yrs. old & better than new! Spacious 3-BR, 2 1/2-BA semi w/many added improvements (privacy fence, security system, water softener, humidifier on heating system, etc.), making it truly move-in ready. MBR suite w/2 WIC, 2nd flr. laundry, kit. w/breakfast area, LR w/gas FP & DR w/tray ceiling. .... \$220,000 ID# 6694431  
KUTZTOWN - Wonderful qualities inside & out! This 3-BR home features original woodwork throughout, newer appliances, utilities & roof, hardwood floors & 1st floor laundry room. Great rear patio perfect for entertaining. Well-maintained yard & gardens. Located near the park. Move-in ready! .... \$169,900 ID# 6793847  
KUTZTOWN - Spacious & immaculate 2-sty. home w/3 BRs, 1 1/2 BAs. Large eat-in kitchen w/an attached DR. 1st flr. laundry. Newer carpet. Oversized 2-car garage. Move-in ready! .... \$164,900 ID# 6768555  
KUTZTOWN - Large storefront in downtown Kutztown, many possible uses, landlord pays heat, water & sewer costs (w/a cap), tenant pays electric. .... \$1,500/mo. ID# 6878526

KUTZTOWN SCHOOLS - Step back in time w/all of the mdrn. conveniences. This one-of-a-kind 2-sty. log house offers a wonderful interior. Gourmet kit., 5 BRs, Japanese soaking tub in master BR, 3 FPs, wood flrs., DR, LR, fam. rm., pottery studio & much more. .... \$275,000 ID# 6870170  
KUTZTOWN SCHOOLS - Cute 3-BR, 2-BA single home in Stony Run offers lg. LR w/built-in storage & versatile flr. plan w/rear rm. that can be a fam. rm. or 1st flr. BR. 2-car detached gar. has additional storage & work area. Great opportunity for investors or first-time home buyers. ... \$89,700 ID# 6854896  
BRANDYWINE SCHOOLS - This 4-BR, 4 1/2-BA, 4000+ sq. ft. home has so much to offer! Lg. rooms, open flr. plan on 1st flr. LR w/FP & vaulted ceiling, beautiful wood flrs., 1st flr. master suite w/jetted tub & balcony. Finished daylight basement offers fam. rm., rec. rm. & extra BR. Nestled on 4 acres. Plus so much more! .... \$399,000 ID# 6823987  
BRANDYWINE SCHOOLS - Wooded 6.44-acre lot near Sally Ann Furnace. Gradual slope uphill from road offers several lovely settings for your new home. Secluded but not isolated. Perked and probed in 2004. .... \$119,900 ID# 6832750  
BRANDYWINE SCHOOLS - Partially wooded and cleared. Stone walls highlight this 4.6-acre lot. Great lot for your secluded new home. .... \$99,000 ID# 6790420

Search By Listing ID# on www.monaghangroup.com or call us for more details!

See all of our properties advertised 24/7 at www.monaghangroup.com

## THE Merchandiser CLASSIFIED AD FORM:

**STEP #1 ENTER YOUR PHONE NUMBER** \_\_\_\_\_

**NAME** \_\_\_\_\_

**ADDRESS** \_\_\_\_\_

(This information is for our records only)

**STEP #2 CHOOSE A CATEGORY YOU WANT YOUR AD PLACED UNDER** - (PLEASE CHECK ONE BOX.)★

<input type="checkbox"/> ANNOUNCEMENTS	<input type="checkbox"/> FARM EQUIPMENT/LIVESTOCK	<input type="checkbox"/> LOST & FOUND
<input type="checkbox"/> ANTIQUES	<input type="checkbox"/> GARAGE/YARD SALES	<input type="checkbox"/> MISCELLANEOUS
<input type="checkbox"/> AUTOMOBILES/TRUCKS	<input type="checkbox"/> HELP WANTED	<input type="checkbox"/> MOBILE HOMES
<input type="checkbox"/> AUTO PARTS & SVCS.	<input type="checkbox"/> HOME IMPROVEMENTS	<input type="checkbox"/> MOTORCYCLE/ATVs
<input type="checkbox"/> BOATS/MOTORS	<input type="checkbox"/> HOUSEHOLD ITEMS/FURNITURE	<input type="checkbox"/> PETS & ANIMALS
<input type="checkbox"/> CHILDCARE	<input type="checkbox"/> REAL ESTATE	<input type="checkbox"/> FOR RENT
<input type="checkbox"/> COMPUTERS/OFFICE		<input type="checkbox"/> RVS/CAMPERS
<input type="checkbox"/> SUPER AD (Bold Type) (\$2.00 additional per ad, per week, per publication)		<input type="checkbox"/> RECREATION/SPORTING GOODS/EQUIPMENT

FREE to Commercial ads

**STEP #3 ENTER YOUR AD EXACTLY AS YOU WANT IT TO APPEAR**  
(Please print legibly...Please use punctuation...One word per box, please)

1.	2.	3.	4.	5.
6.	7.	8.	9.	10.
11.	12.	13.	14.	15.
16.	17.	18.	19.	20.
21.	22.	23.	24.	25.
26.	27.	28.	29.	30.
31.	32.	33.	34.	35.
36.	37.	38.	39.	40.

**STEP #4 CHOOSE A PUBLICATION**  
DEADLINES FOR ALL CLASSIFIEDS IS THURSDAY, 5:00 PM)

East Penn Valley Merchandiser (Reaches over 40,481 Homes)

Northern Berks Merchandiser (Reaches over 31,056 Homes)

Both (Cost Would Be Double) (Reaches over 71,537 Homes)



**STEP #5 ENTER NUMBER OF WEEKS YOUR AD IS TO RUN:**  
(PLEASE CHECK ONE BOX.)

Run:  1 Week  2 Weeks  3 Weeks  4 Weeks  \_\_\_\_\_

Enter Starting Date Of Ad \_\_\_\_\_

Total Amount Paid \$ \_\_\_\_\_ Check # \_\_\_\_\_

**STEP #6 CHOOSE METHOD OF PAYMENT**  
(PAYMENT MUST ACCOMPANY AD)

We Accept Cash, Check, Money Order,   



Credit Card Information: NAME ON CARD \_\_\_\_\_

ACCOUNT # \_\_\_\_\_ EXP. DATE \_\_\_\_\_

TYPE OF CARD: VISA \_\_\_\_\_ MasterCard \_\_\_\_\_ Discover \_\_\_\_\_ CVC Code: \_\_\_\_\_

SIGNATURE: \_\_\_\_\_

Mail Ad With Payment To: THE WINDSOR PRESS, INC., PO Box 465, Hamburg, PA 19526-0465  
Bring Ad and Payment To Our Location At: 6 North Third St., Hamburg, PA 19526  
Place Your Ad By Phone By Calling 610.562.2267 or 1.800.220.3053

Please have your    account number and expiration date available.

We Are Not Responsible For Incorrect or Inaccurate Information or Mistakes Either in The Classified Ads or In Any Other Advertisement In This Paper.

For Your Convenience, Place Your Ad: By Phone: 610.562.2267 or 1.800.220.3053 FAX: 610.562.2770

E-Mail: classifieds@windsorpress.com  
OR USE THE CLASSIFIED AD FORM ON OUR WEBSITE: www.windsorpress.com

CARD OF THANKS DISPLAY AD \$17.50 Per Publication EMAIL: display@windsorpress.com

RATES:

**REGULAR AD:**  
Up to 20 words \$4.80 per issue per week. Additional words after 20 - 10¢ each

**COMMERCIAL Ad:**  
Up to 20 words \$7.90 per issue per week. Additional words after 20 - 10¢ each

Commercial ads include any person or group normally engaged in offering goods or services in a business environment and include: Rentals, Items Manufactured or Bought for Sale or Resale, Babysitting Service, Help Wanted, Business Listings, etc.

UNDER RULES ESTABLISHED BY THE PENNSYLVANIA HUMAN RELATIONS ACT, ANYONE WISHING TO SELL OR LEASE RESIDENTIAL OR COMMERCIAL PROPERTY OR SEEKING TO HIRE AN EMPLOYEE CAN MAKE NO REFERENCE IN THEIR ADVERTISING TO SEX, MARITAL STATUS, AGE, RELIGION, ETHNIC BACKGROUND, RACE, COLOR, DISABILITY, CHILDREN OR SUPPORT ANIMALS. Special Instructions: We will try to print your classified ad in the next issue after receipt, but reserve the right to hold for the following issue. Please write legibly. Please use only one word per space. Each word in a business name or address will count as one word.

Page 5

www.windsorpress.com

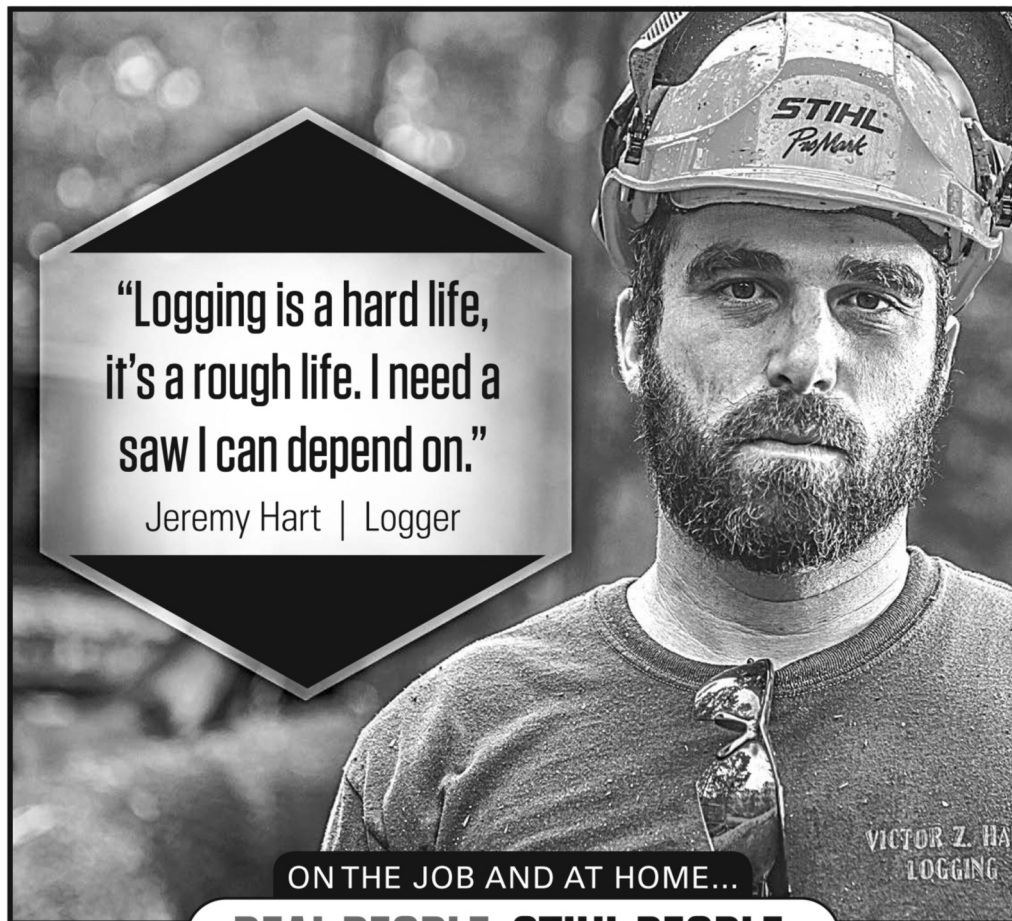

**"Logging is a hard life, it's a rough life. I need a saw I can depend on."**  
Jeremy Hart | Logger

ON THE JOB AND AT HOME...

**REAL PEOPLE. STIHL PEOPLE.**



**NEW! BR 700 BACKPACK BLOWER**  
**\$549<sup>95</sup>**

The most powerful backpack blower in the STIHL lineup





**MS 271 FARM BOSS®** **\$379<sup>95</sup>**

★★★★★ 16" bar<sup>1</sup>

"I have owned other saws in this class and the MS 271 has the best power to weight ratio that I have owned."

- user Tommy80



**50% OFF WOODSMAN CARRYING CASE**

WITH PURCHASE OF SELECT STIHL CHAIN SAWS

**JUST \$21<sup>49</sup>**

A \$42.99 NES-SRP. Offer valid with purchase of MS 271, MS 291, MS 311, or MS 391 chainsaw 7/18/16 through 12/31/16 at participating dealers while supplies last.

Check out this review and others on the product pages at STIHLdealers.com.

CHAIN SAWS STARTING AT \$179<sup>95</sup> | BLOWERS STARTING AT \$139<sup>95</sup> | TRIMMERS STARTING AT \$129<sup>95</sup>

**Bechtelsville**  
Passmore Service Center  
1108 RT. 100  
800-618-8550  
PassmoreSC.com

**Leesport**  
Reading Tractor  
5538 Pottsville Pike  
6109262441  
ReadingTractor.us

All prices are NES-SRP. Available at participating dealers while supplies last. Northeast STIHL services dealers in CT, MA, ME, NH, NJ, NY, PA, RI, VT. <sup>1</sup>The actual listed guide bar length may vary from the effective cutting length based on which powerhead it is installed on. © 2016 STIHL NES16-1121-130033-10

**BUILT IN USA** Indicates products that are built in the United States from domestic and foreign parts and components.

**STIHLdealers.com**

**DESIGN BUILT CONSTRUCTION**

New Homes • House Additions  
• Renovations • Kitchens & Baths

Contact John Scully



14558 Kutztown Road / Fleetwood, PA 19522  
Phone: 610-683-6120 Fax: 610-683-9132  
www.mccbuid.com HIC Registration # PA 8177

**SEASONAL EQUIPMENT**

Keystone KB8 coal stoker boiler with domestic hot water coil. Never used \$5800. Also 10,000btu window or wall A/C unit \$100. 570-640-7891.

**SEASONAL EQUIPMENT**

Quadra Fire Gas Direct vent room heater. Sapphire Model 30,000 BTU's. Warming shelves, Mahogany color \$750; 484-857-3135.

**SEASONAL EQUIPMENT**

SNAPPER 10hp Rear Engine Riding Mower. 28" deck, double bagger system, electric and pull start, just serviced, great condition, \$400 obo. 484-388-1986.

**MOBILE HOMES**

**BUY DIRECT: Modulares, Double wides, single wides. Starting at \$35,900. We will not be Undersold! We Accept Trades. 717-875-1288.**

**Drive A Little, Save a Lot! Free delivery and Set up! New single wides \$34,900; Double wides \$45,900; Modulares \$59,900; We will not be undersold. 717-875-1288.**

**ATTENTION Mobile Home Owners! Specializing in Mobile Home Repairs and Updates. Complete Remodeling Kitchen and Bathroom, Doors, Windows, Flooring, Plumbing Repairs, Water Heaters, Heat Tape Replacement. Total service inside and out. 30 yrs. Experience. Call Blue Mt. Home Renovations, Ask for Bob at 610-554-5070.**

**SENIORS, ENJOY A RETIREMENT ENVIRONMENT FOR LESS THAN RENT! Can Meet All Budgets! 5 beautiful 55 & older age restricted land/lease Retirement Communities: Wernersville, Kutztown, Fleetwood & Bernville areas. Well maintained singles (12x68 to 14x70) from \$14,999 to \$29,999. New and pre-owned doubles (20x44 to 28x66), 2 with carports, from \$24,999 to \$98,500. Lap/shingle. Loaded with goodies! Move in conditions! Lowest monthly fees! Visit www.kellerhousingcommunitiespa.com for photos & details. Sorry, NO dogs. Keller Homes. 610-944-7696.**

**MOBILE HOMES**

**14'x60' Single wide trailer. Two bedrooms, one bath, living room, eat-in kitchen includes fridge, stove. Newly painted exterior well maintained. 8'x11' deck. RV awning attached. Price does not include moving trailer. \$4000. 631-875-5684.**

**Boyertown Area Mobile Home NEW: 2016, 3 BR, 2 BA, C/A, on large lot, with garage and carport, \$45,000. 610-845-3349.**

**FOR RENT**

**APARTMENT: Richmond Twp., 2 BR on 2nd level. Recently remodeled bath. Off st parking. \$875/month includes heat, electric, water, sewer and trash. Call 610-944-7116 and leave message for Dave.**

**APARTMENTS FOR RENT W/W Carpet, Total Electric, 1 yr lease, No Pets \$550-\$650 mo. Plus Security. All 1 bedroom. Free Internet, near Crystal Cave. Call 610-737-8306.**

**For rent in Lyons 2BR Apt. 2<sup>nd</sup> floor, refrigerator, stove, total gas, \$700/mo. Plus utilities. Water, sewer and trash included. 484-256-2240. Available Now.**

**FOR RENT: Storage Units Lyons, 10x17 \$80 (three unit), call 610-845-7796.**

**Office/ Professional/ Retail space for rent, highly visible location at 400 S 4th St. Hamburg, formerly occupied by Quest Medical Lab. Appx. 600 square feet Large open room and smaller office, plus restroom. 9½ Foot ceilings, large off street parking area right at the door and sign post available. Well suited for professional office, retail or personal trainer/ small fitness center, etc. \$750 per month plus electric. Call Fred at 610-618-0984.**

**COUNTRYSIDE COAL Delivery Service**

Anthracite Coal - Hard - Medium Hard  
All Sizes - Courteous Delivery Service  
**717-933-9263 717-269-0804**

WE SELL BLASCHAK COAL

DAVID W. ROHRER, PROP.

**FOR RENT**

**1 BR & 2 BR apts. available on Main St., Shoemakersville. TEXT Pref/ Call 610-914-5911.**

**FOR RENT**

**APT FOR RENT: 2<sup>nd</sup> floor \$650/mo. 16 Home Ave, Topton. No pets, Call 610-682-2722.**

**GEORGE MILLER IV AUCTION CO. SELLS PUBLIC AUCTION**

**CONTENTS OF GUNTHER'S AUTO BODY REPAIR SHOP**  
Thursday, October 27, 2016 at 2:30 P.M.

Location: 105 Lobachville Rd., Rockland Twp., Berks Co., Fleetwood, PA 19522.

**Items Featured:** Grizzly Indus. sheet metal braker; auto air lift; Uni-Ram cascade spray gun cleaner; Airco Arc equip.; paint shaker mach.; Black Hawk floor pulling system for body repair; Craftsman: 15" drill press, 6" bench grinder, 16" scroll saw, 10" miter saw, 14" chop saw; Campbell Hausfeld air comp; Pluse 1850 generator; tool chests; lg asst. of mech. hand tools; paint spray guns; log splitter; Husqvarna chain saw; algar; Harman rice coal stove; 2 titled trailers; cement mixer; rowboat; beer signs; NASCAR coll.; Lionel trains; Plasticville houses; air shooting target; hunting clothes & books; plus more!! **Terms:** Payment day of sale. Cash, guaranteed funds; No out-of-state checks. See www.auctionzip.com ID# 4715.

**GEORGE MILLER IV AUCTION CO.**  
Auctioneers, Appraisers, Consultants  
PA# AU-003073-L • Ph.: 610-944-0926  
Fleetwood, PA 19522  
george.millerIV@gmail.com



**Selling for THE LATE GARY GUNTHER**  
Terms by Linda M. Gunther

**GEORGE MILLER IV AUCTION CO. SELLS REAL ESTATE AT PUBLIC AUCTION**

**18+ ACRES, STONE FARMHOUSE, ANTIQUES, COLLECTIBLES, HH, LAWN EQUIP., AUTOS**  
Sat., Nov. 26, 2016 at 9:00 AM. Real Estate at 12:00 Noon.  
Location: 60 Delcamp Rd., Fleetwood, Berks Co., PA 19522.

**RE Features:** 2-1/2 sty stone & frame farmhouse w/a very private setting back a long lane. 3 BRs, mod. kit., LR, DR, full bath on 1st fl., basement, stand-up attic, encl. porch, CA, summer kit., 2-sty frame workshop, bank barn, cottage w/2 BR, kit., LR, full bath, presently being rented. Same ownership since 1973. Plenty of wildlife. Country living at its best!!!! Come take a look! Op. Hs.: Oct. 29, 9:30-11:30am & Nov. 5, 9:30-11:30am or by appt. **Terms:** 10% down day of sale. Settlement on or before 60 days. Cash or guaranteed funds.

**GEORGE MILLER IV AUCTION CO.**  
Auctioneers, Appraisers, Consultants  
PA# RY000140L • Ph.: 610.944.0926  
Fleetwood, PA 19522  
george.millerIV@gmail.com • Auctionzip ID#4715



**Selling for JANE A. DELCAMP**  
Gary M. Kramer, POA



**610-683-7880 • Kutztown, PA**

[www.safeandsoundauto.com](http://www.safeandsoundauto.com)

**Dedicated to your safety!**

**Safe & Sound Fall Driving Maintenance Special**

**Don't Forget Our Convenient Vehicle Pick Up & Delivery Shuttle Service**

- Includes Wix Premium Oil Filter
- 5 qts. Standard Motor Oil
- Inspection of All Belts & Hoses
- Check & Fill All Fluids
- Tire Rotation
- Brake Inspection
- 30 Point Courtesy Check

**\$39.95**

[www.safeandsoundauto.com](http://www.safeandsoundauto.com)



# BETTER HEAT NOW LOWER BILLS LATER



Only **Stoves 'n Stuff** offers all your alternative heating options: Wood, Coal, Gas and Pellet Stoves, Fireplaces and Inserts

Quality hearth products provide lasting warmth.



**TAMAQUA**  
(570) 386-5656

**STROUDSBURG**  
(570) 424-2421

**EMMAUS**  
(610) 966-2271



### DAN'S TREE & PROPERTY MAINTENANCE

Tree Removal/Trimming  
Bush Removal/Trimming  
Brush Removal/Pruning  
Lawn Mowing  
Small Engine Repair

Fully Insured • Free Estimates  
Dan Waldrop 484-793-0049

#### FOR RENT

For Rent Lenhartsville 1st floor, 2 bedroom apartment. Off street parking. Heat, water, sewer, trash included. \$750/month. W/D hook up. No pets or smokers. Security deposit 484-788-2935.

Storage Garage: Approx. 24x24, 12ft. Door, Limeport Area, \$150/mo. 610-965-2931.

## THE EMMAUS KIWANIS CLUB FRUIT SALE



Tree ripened **ORANGES** and **GRAPEFRUIT** from Florida. All fruit is guaranteed perfect. Picked, packed & shipped within the same week for its flavorful best.

**FRUIT CAN BE ORDERED FROM ANY  
KIWANIS MEMBER OR CALL 610-395-4818  
or ONLINE at www.emmauskiwanis.org**

Help the Emmaus Kiwanis Club to fund community projects and enjoy the finest vitamin rich fruit.

Order by Nov. 6th, Pick up Dec. 2nd at JAS Wholesale (Rt. 29 & Colebrook Ave. - Across from Pickles Restaurant)

	2/5 Bushel Box	4/5 Bushel Box
NAVELS .....	\$26	\$34
TANGELOS .....	\$26	\$34
RED GRAPEFRUIT .....	\$26	\$34
MIXED CASE .....	\$28	

(1/2 NAVEL - 1/2 GRAPEFRUIT)

Ask Us About Our Holiday Pies - \$11.00 each.

### B. Young

## Asphalt Paving and Sealcoating

Free Estimates Kutztown

**484-486-0282**

PA #111185 • Driveways • Parking Lots • Hot Crack Repair • Gravel

**NEWLY REMODELED** Executive two bedroom apartment with a loft in Orwigsburg. Includes W/S/T and heat. \$1000 per month. No smoking or pets. 570-516-1881.

Storage For Rent, Car, Motorcycle, Household Items, Clean and Dry, 10x25, \$120 Monthly, other sizes available, call for rates, Lyons Area, 610-295-7681

#### AUTO PARTS & SERVICES

5 GOODYEAR WRANGLER TIRES 33x12.50.15LT raised white lettering, over 1/2 inch tread \$475. One was for spare. Also muffler and tailpipe from 2012 Ford F-150 4x4 X-Cab 5.0. Only had 500 miles on \$225. Also muffle tailpipe off 2014 Ford F-250 4x4 4-door 6.1 engine only 750 miles on \$250. Call 610-966-8579.

**STEVE'S BRITISH CAR**, British auto repair and restoration. I have over 35 years experience. I am ASE MASTER TECHNICIAN; I can handle any job on your British car. I buy cars, too. stevesbritishcar.com or Call 610-207-7651.

Trailers + Snowplows + Hitches + Parts and Service. Special: All 2016 new Ringo Trailers in stock Only; receive a FREE Spare Tire & wheel. Grim's Trailers, 299 Fleetwood Road, Mertztown PA 19539, 610-682-7018.

#### GARAGE/YARD SALES

Huge estate and multi family garage sale. Friday Oct 28, 2-6, Saturday Oct 29, 8-2, Sunday Oct 30, 8-2. 40 Coal Mountain Rd. Auburn. Inside and outside. Vintage and antique items. Clothes, small Atlas metal lathe, commercial muffin pans, records, cut glass, sets of dishes, Pyrex, vintage air compressor, hay elevator, Christmas items, HD ultra seats and parts. Too many items to list. Rain or shine.

Huge Yard Sale 10/28, 7-4. 10/29 7-12. Household, primitives, Longaberger, clothing, toys, dye cast race cars, and more. 111 Fredericksville Road, Mertztown.

Last chance till Spring! Find a unique Christmas gift for that hard-to-buy-for person! John Deere and International toys in boxes, vintage tools, old books/ Bibles, foot powered knife sharpening grindstone, antique anvil- vise, antique post drill, working John Deere Model 50 tractor. October 28-31, 8-5. Route 737 and Kunkels Mill Rd., Kempton. Rain or shine.

Saturday 10/29 and Sunday 10/30, new and used plus size clothing and more. 328 Luella Dr. Kutztown. Rain date following weekend.

YARD SALE: Friday October 28th 8am-2pm. Saturday 29th 7am-11am. 43 N Richmond Street (rear) Fleetwood. Jewelry, glassware, Christmas decorations, Barbies, Cabbage Patch dolls, Longaberger baskets, cookware, clothing, shoes and lots more. Rain or shine.

#### HOUSEHOLD ITEMS/ FURNITURE

BOWFLEX XTREME 2 SE, many attachments included, DVD and manual, Asking \$800 obo; Hotpoint 30" white Gas Range, oven never used, \$200 obo; Edenpure US 1000 Heater \$20 obo; Craftsman 10" Table Saw with Stand \$100 obo; Weber Performance Deluxe 22" Gas Grill with propane push button ignition \$125; Call 215-679-6082.

**FOR SALE: Used washers, dryers, refrigerators, freezers, electric and gas ranges, 30 day guarantee. Phone Lesh's Appliances M-F 8 to 5 @ 610-562-8577.**

New Dehumidifiers In Stock. 30, 50 & 70 pints. David's Electric, Emmaus 610-965-4282.

Reconditioned 17 cu. ft. Refrigerator with top Freezer. Glass shelves, \$350 Guaranteed. David's Electric, Emmaus 610-965-4282.

Tapking 2 Tap Kegster with tap handles. Needs some cleaning. Cools well. Holds a quarter keg and a mini keg. Does not hold sixtels. 610-295-9152.

#### RECREATION/ SPORTING GOODS

**DEER HUNTERS: 100% Pure PA Doe In Heat. No additives or preservatives. Chris's Outdoor Sports, 610-682-4129.**

#### RECREATION/ SPORTING GOODS

**FISHERMEN: Live Bait Year 'Round. Chris's Outdoor Sports, 610-682-4129.**

#### NEW TRIPOLI, LEHIGH CO.

### PUBLIC AUCTION

**ANTIQUE JD TRACTORS - OLIVER CRAWLER, IH ENGINE, FARM EQUIP., FEED BINS, SILVER COINS, ANTIQUES, PRIMITIVES, BUTCHERING ITEMS, FURNITURE, TOOLS & TOYS**  
Friday, October 28, 2016 at 8:30 A.M.

Location: 6648 Milo Rd., New Tripoli, PA 18066 (Lehigh Co.). Directions: From Kempton follow Kistler Valley Rd. towards Lynnville for approx. 3 miles. Turn left onto Golden Key Rd. (Rt. 863 North). Go 1 mi., bear right onto Scholler Rd. Go 1/2 mi., keep right onto Scholler Rd. Go 1/2 mi., keep right onto Milo Rd. follow to auction. Watch for signs.

**Antq. Tractors, Crawler & Eng.:** '58 JD 730 diesel, elec. start, NFE, 2-pc. front weights, 3 pt., 5517 hrs., ser. #7300837 - 1 owner!; '59 JD 630 NFE, flat-top fenders, 3 pt., 5743 hrs., ser. #6303392; '51 JD B, NFE rollamatic, hyd., PTO, ser. #292623 (sells w/bucksaw); '45 JD 'A', NFE, PTO, hyd., loader, ser. #552019 (eng. tight); Oliver Cletrac HG crawler trctr. (eng. tight); International 1 1/2-hp kero./ gasoline eng., ser. #A-47451, 3-pc. front wght. set for 630 or 730; JD top-link for 630 or 730; 2 JD whl wghts., PTO shield for 730 & other JD parts; Cub Cadet 147 hydrostatic w/tiller & snowblower. **Farm Equip. & Feed Bins:** Bush Hog 10' offset disk; JD 215 12' disk; JD 11-tooth chisel; 12' & 10' cultimuchers; JD 5x16" & 4x14" semi-mount plows; JD 8250 8' 14-row grain drill w/grassboxes; JD 8' 3-pt. blade; Westfield 8"x50" transport grain auger (PTO drive); Speed King 8"x50" grain auger; White 6-row corn planter (as is); NH67 baler (as is); JD 444 4Rx36" corn head; 6"x16" alum. elevator; dump wgn.; running gear; Ford 340 Skid loader (for parts). **Grain Bins (To Be Removed By Buyer):** MFS 24"x21" w/drying flr. - 7700 bu.; Circle 30"x13" - 7500 bu.; Butler 18"x18" - 3800 bu.; 2 JD sickle bar mwrs. (rear mount); set of cultivators.

**TOOLS & MISC.:** Torch set, Dayton metal band saw; 2 elec. fencers, Flowtron elec. log splitter; Trek tricycle; wdn. bolt bin w/misc. parts; misc. wrenches & tools; scrap iron (some brass & copper); misc. equip. parts & more unused. **Butchering Items, Antqs. & Primitives:** 20"x114" butcher bench w/3" thick top; Enterprise 32 meat grinder on bench; Enterprise sausage stuffer; wdn. scalding trough; hog scrapers & turning chains; meat hooks; meat saw; Foster Bros. meat clever; ladles, forks & knives; CI fry pans; Griswold #8, Erie #8, Puritan #8; 4 CI furnace kettles; twin CI furnace top & front (marked F. Earl Landis, Brunnerville Foundry, Lanc. Co., PA; drying pan; metal egg shipping crate; Stoneware crocks & jugs; Stoneware chicken waterer; beam scales; old strap hinges; adz; shoe lathe; wdn. block plane; 2-man crosscut saw; Cant hook; 2 scythes; 2 peening anvils; wdn. barrel butter churn; few antq. quilts; wedding dress; wdn. boxes: Sandford's Inks, Lehigh Valley Dairy & others; Enterprise #602 grinder; CI implement seat; wdn. merchandise cab. w/6 drwr.; Columbian bench vise; anvil; ice saw; ice tongs; wdn. rake; PA 1954 & other license plates; 2 drawing knives; washboard; wdn. neck yokes; 2 horse hitch; RR lantern (No. 20 - by C. Tham Mfg.); metal signs: Master mix 16"x30", Henry Gruber 10"x14", Lehigh Co. Ag., PA Beef, etc.; porcelain soap sign; porcelain lamp; 2 early wdn. thrashing flails - nice orig!; 2 & 3-prong thrashing forks; fishing basket; 3 hand crank dusters; grn. & blue jars; Ziegler, Rdg., PA 1-qt. mik bottle; coffee grinder; Enterprise cherry stoner; 2 slaw cutters; wire rug beater; Flying Arrow sled; lead dipper; old pullies; Horn cloth bag seeder; 2 sm. wdn. barrels; Keystone dehorner; wdn. shutters; old drs. & windows; wdn. beams & lumber; 3 Western saddles; lthr. fly nets; wdn. feed or seed chest; (1) 10' & 6' CI water troughs; corn sheller; The Clipper grain cleaner; Dellinger hammer mill; 6" flat belt; Fairbanks platform scale. Toys: 2 Marx wind-up crawlers, Hubley Kiddie Toy, Tootsie Toy, Fisher-Price, Hotwheels, Matchbox, etc.; cap guns; baseball & football cards. Antq. Furn.: Tbls.; chairs; beds; Standard treadle sew. mach. w/cab., pntd. secretary desk; Majestic tube radio; glass-frnt. disply cab.; kneehole desk; misc. glassware & much, much more. **Coins: Call auctioneer for coin catalogue @ 717-354-9524. (2)**

1921 Morgan, (3) 1922 Peace & (3) 1923 Peace silver dollars; 1809 Capped Bust, lettered-edge half dollar; 1857 Flying Eagle cent; 1864, 1902, 1903 Indian Head cents; 1852 Silver Trime (3 cent); 1865 nickel 3 cent pc.; 1887 V-nickel; 1774 coin (England); (74) 1930-1950s Washington quarters; (100) 1960-1964 Washington quarters; 3 Standing Liberty quarters; (14) 1937-1945 Walking Liberty halves; (14) 1952-1963 Franklin halves; 16 Mercury dimes (1930s & 1940s); 100 Roosevelt dimes - pre 1964; (11) 1964 Kennedy halves; (36) 1965 to 1968 Kennedy halves; (120) 1971+ Kennedy halves; wheat pennies; buffalo nickels; (22) 1957 & (1) 1935 \$1 Silver Certificates; 1913, 1917, 1919 Canada lg. cents; 48 Red Seal \$5 bills; (20) 1976 \$2 bills. **Auction Info.:** Take a step back in time & join us as we sell these antqs. from the Gruber Homestead. Many interesting items. Auction will begin at 8:30 w/misc. antqs. Coins will sell at 11:00. Farm Machinery & Trctrs. at 1:00. Possibly sell w/2 auctioneers. Auction Co. & sellers are not responsible for accidents. Auction day announcements take precedence over all advertising. Payment by cash, good PA check or credit card w/3% fee. No buyer's prem. Food stand. In case of inclement weather, auction will be held in tent. Call auctioneer @ 717-354-9524 w/any questions.

See more @ auctionzip.com, ID#25403

**TIM WEAVER**  
**DAVE STOLTZFUS**  
Lic. #AY2109  
717-354-9524

**Auction For:**  
**HARRY GRUBER**  
& **BERTHA**  
**MARTIN**

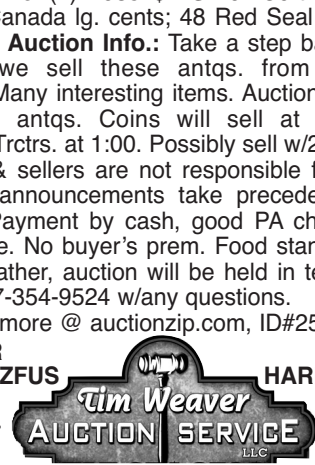

Honesty • Integrity • Commitment

## Complete Driveline Service

CV Shafts  
PTO Shafts  
Car & Truck Shafts  
Industrial Drive Lines



machining & fabricating specialists since 1936

3417 Pricetown Road,  
Fleetwood, PA 19522  
610-944-7455

Mon. - Fri. 7 a.m. to 4:30 p.m.  
www.levanmachine.com

**Better Service**  
**Lower Prices**  
**Greatest Availability**

# AT YOUR SERVICE FOR ALL OF YOUR ADVERTISING AND PRINTING NEEDS!

## PRINTING & ADVERTISING SERVICES AVAILABLE

### General Products

- Business Cards
- Brochures
- Letterheads
- Envelopes
- Newsletters
- Tags & Time Cards
- Postcards
- Tablets & Order Pads
- Salesbooks
- Menus
- Posters
- Tickets
- Gift Certificates
- Calendars

### Specialty Items

- Wedding/ Anniversary Invitations
- Graduation Announcements
- Cards & Announcements
- Custom Ring Binders
- Presentation Folders
- Custom Post-Its™
- Membership Cards
- Holiday & Christmas Cards

### Ad Specialties

- Coffee Mugs
- Calendars
- Hats & T-Shirts
- Pens & Pencils
- Trade Show Giveaways

### Ad Services

- Artist Services
- Logo Design & Illustration
- Advertising Campaigns
- Advertising Agency



### Books

- Employee Books
- Annual Reports
- Manuals
- Ad Books
- Program Books
- Cookbooks

### Capabilities

- 4-Color Process (Web & Offset)
- Laser Thermography
- Collating
- Stapling
- Drilling
- Folding
- Perforating
- Numbering
- Laminating
- Copy Services

### Business Forms

- Invoices
- Delivery Receipts
- Continuous Forms
- Mailers
- Statements

### Envelopes

- Booklet Envelopes
- Check Envelopes
- Business Reply/Return
- Commercial Envelopes
- Security Envelopes

### Labels & Stickers

- Food & Product Labels
- Individual/Pinfeed/Fanfolded/Sheets
- Laser Labels
- Decals & Bumper Stickers
- Shipping Labels



6 North Third Street, P.O. Box 465  
 Hamburg, PA 19526-0465  
 610.562.2267 or 1.800.562.5521  
 FAX: 610.562.2770  
[www.windsorpress.com](http://www.windsorpress.com)



**Gates**  
**HYDRAULIC HOSES**  
 STONEY CREEK RENTALS  
 www.stoneycreekrentals.com  
 872 Park Road, Blandon, PA 19510 • 610-926-4567

**FINAL WEEK!** Wed., Oct. 26 thru Sat., Oct. 29  
 7th Anniversary **Sale-A-Bration** **LOTS OF SUPER SPECIALS STOREWIDE**  
 Free Gift While Supplies Last w/ Purchase  
**Believe It!**  
 CONSIGNMENT BOUTIQUE  
 Jr. & Women's New and "Like New" Brand Name Clothes & Accessories  
 1543 Old Rt. 22, Lenhartsville, PA 19534  
 610-562-5532  
 www.believeitconsignments.com Wed. & Fri. 11 am-5 pm; Thurs. 11 am-6 pm & Sat. 11 am-4 pm

**RECREATION/SPORTING GOODS**  
 I Buy Old Ammo., Hunting Licenses, Knives, Swords, Traps, Powder Horns, All Guns, Weapons and Related Gear. Serious Cash Paid. House Calls Made FREE: P.J. 610-417-0909.

**SERVICES**  
**HILLTOP Sharpening Service**, Meeting your sharpening needs. 1/2 mile north of Bowers Hotel, on Bowers Road. 395 Bowers Rd., Kutztown, 19530. 610-682-6141.

**ADAM'S TAXIDERMY**  
 Whitetail Deer, Bear and Shoulder Mounts  
 Life-size Mammals & Small Game  
**COME SEE OUR LARGE SHOWROOM!**  
 We Also Do African & Exotic Life-size & Shoulder Mounts  
 In Business 38 Years! In HIS Service!  
 1348 DORNEY ROAD • MERTZTOWN 610.682.2414

**SERVICES**  
**\$98 Heating Check UP:** Call to Schedule. Locally owned and operated. HVAC heating and air conditioning service and installation. J.P. Works 610-597-4810. Email jpworks@ptd.net PA#115527.  
 Chimney Repair & Rebuilds. Stone, Brick & Block. Call 610-750-4416 for a FREE Estimate. Please leave message.

**BRENT'S TREE SERVICE:** Specializing in Topping, Trimming, Tree Removal, Stump Grinding. Truck and Chipper Equip. Fully Insured. Many years experience. Free estimates. Call 610-966-4279, Albur-tis.  
**JOE'S CONCRETE REPAIR.** Repair and save \$\$ Small job specialist. Steps, sidewalks, walls, foundations and more. Call 484-347-9804. Emmaus.

**ADVERTISE**  
 In the East Penn Valley & Northern Berks  
**Merchandisers**  
 Call The Windsor Press, Inc. 610-562-2267 1-800-562-5521 www.windsorpress.com

**9th D&J CONSIGNMENT AUCTION SAT. OCT. 29th, 2016 at 9:00 A.M.**  
 Location: 740 Noble St. Kutztown.  
 At Renningers Farm Markets in Kutztown  
**Tractors:** MF 283, JD4500 both very nice, Ford TN65, Kubota L210 both good tractors. MF275,  
**Equipment:** Peck 12" 43ft Transport auger (like new) 6" 30ft & 45ft trnsprt augers, Hesston 740 round baler (like new), NH 145 Spreader (nice), IH 600 & NH 23 silo blwrs, IH #8 Flail chppr, Pequea 710, 910 & 2 star Tedders, NH 488 Haybine, JD 8' & 12' transprt discs, NH 880 Harvstr, 300 gal sprayer, Metal rack wagon & flat wagons, 36ft mayrath elevtr, JD 400 rotary hoe, NH 256 & 258 rakes, 8ft Bushhog offset disc, Grove 707 running gear, IH 4500 field cultvtr, 5 T Athens pull type chisel, 8T chisel, 8ft, 9' 10' 11' & 12' Cultipackers some Brillion. JD 1240 plateless corn/soybean planter (new discs), NH 68 Baler, IH 45 Baler, JD Sicklebar mower, small Millcreek spreader, NH 452 disc mower, 7ft trnsprt disc, gravity bins wagons,  
**Plows:** 1 bt, 2 bt JD, 2 bt AC, 2 bt MF, 3 bt Oliver, 3 bt MF, 4bt IH 710 auto reset, IH 6 bt, All 3 pt plows. 1 bt and 2 bt JD trailer plows (nice),  
**Misc Equip:** Snowco grain cleaner, 7ft MF weeder, MF 6ft disc, York stone rake, pull type Cosmo Fertilizer sprdr, 5' 6' & 7' 3pt scraper blades, Landpride RCR 1860 brushhog, 30x90 Cattle feedrs, PTO Genrators, 2 wheel horse cart, wheelbarrows, pasture drag, 4" 20ft auger, 6ft chainlink privacy fence, Goodyear 28Lx26 combine tire & other tires, 3pt cultvtr, Hoover outdoor furnace, 15kw PTO generator,  
**Skid Steer Attachments:** Stout 72" rock grapple, 66" brush grapple & 66" grpple bucket, used grpple bucket, 66" & 78" buckets, Pallet Forks, misc used buckets, tree stump bucket, Bale spears, 6 ft & 7 ft fork extensions, 9" post hole augers,  
**Lawn & Garden:** Go Cart, 1953 Gravely w/sulky & sicklebar, JD 225z Zerturn, JD L110, Cub Cadet 80, Homelite RE8E mowers, Snapper push mower, JD 7 & other pull type carts, Simplicity chipper/shrddr, Garden star tiller, 25 Gal Spry, 30" brushmower for gravelly, 44" snowblwr for Gravelly tractor, Black Walnut Lumber, other misc lumber,  
**Tools:** Acetylene Torch (complete outfit), Misc concrete tools, There are always a large amount of hand tools, power tools, shop tools, and misc, always under the large pavilion. Some items subject to prior sales  
 Food Stand Lots of Homemade goodies.  
**Auction By: D&J CONSIGNMENT AUCTION**  
 Auctrs: CLARENCE SHIRK AU3757L & ERIC ZETTEMAYER AU005210  
 Contact David Nolt @ 610-914-1248 or Jason Martin @ 610-223-8510

**SERVICES**  
 Certified Wood Pellet Stove Cleaning and Installation, 3-4 hours to clean units, remove motors, clean housings and impellers, Certified Technician, over 850 wood pellet stoves installed, 20pt safety inspection, Watch and learn, early season special price call 484-529-3876.  
 Home Health Aide: Will care for your loved one. Adult daily living, cooking, light cleaning, etc. Call 610-845-0382.

Serving the area for 120 years, Eddinger specializes in Propane Gas Service to farm, home and industry.  
**Eddinger Propane Gas Inc.**  
 is located at 1619 Route 100 in Bally  
 Hours: Monday through Friday 7:30am to 5:30pm, Saturdays 8:00 am to 12:30 pm, Closed Sunday  
 610-845-2091  
 800-898-Fuel  
 Large - \$599  
 The Ultimate Cooking Experience™  
 BigGreenEgg.com  
 1619 Main St., Bally  
**EDDINGER** SINCE 1890  
 eddingerpropane.com

**DAN'S PLUMBING** Repair Service Albur-tis, Offers full Commercial Residential Plumbing Services. Fixture Repair, Replacement, Water Heaters, Gas and Electric, Water Treatment, Drain Cleaning, Kitchen and Bathroom Remodeling. Call 610-966-5249 or 610-730-2401 cell number.  
**HOME REPAIR & REMODELING:** We Offer Full Home Services from Small Repairs to Complete Homes. Call Us about your Project! Martin Construction 610-683-6120.

**BURKHOLDER'S FARM FRESH PRODUCE**  
 55 Stump Road, Fleetwood, PA 19522 610-944-8380  
 1 mile East of Fleetwood, conveniently located along the Fleetwood-Lyons Road  
**Fresh Sweet Corn** STILL PICKING  
 •Pumpkins •Neck Pumpkins  
 •Edible Squash •Tomatoes  
 •String Beans  
 •Chow Chow •Jams & Jellies  
 •Pickled Beets  
 •Bread & Butter Pickles  
**Fall Mums** \$4.95 ea. or 3/\$13.00  
**Farm Fresh Cage-Free Eggs**  
**Homemade Baked Goods**  
 Fruit Pie, Shoofly Pie, Sticky Buns, White Bread  
**Homemade Penna. Dutch Corn Pie** ..... \$5.75  
**Order Your Ducks For Thanksgiving**  
 \$3.15 lb. Live \$1.75 lb. Dressed  
 We Accept Credit Cards & FMNP Checks

**QUARRY RIDGE ROOFING & SIDING CORP.**  
 153 Quarry Road Kutztown, PA  
 610-683-5312 (Phone)  
 610-683-3207 (Fax)  
 Featuring Everlast Roofing's New OMNI panel...manufactured for  
**Everlast Roofing, Inc.**  
 OUR NAME SAYS IT ALL  
 • Superior strength • Long lasting durability  
 • Attractive design • Weatherright sidelaps  
 • Limited Lifetime Warranty

**SERVICES**  
 Custom Construction: Professional Quality Craftsmanship. Carpentry Services. All phases of construction: Bathroom, Kitchen and Basement Remodeling Door and Window replacement, Renovations, Additions, Porch, Deck projects. Interior/exterior Painting. Deck refinishing. Licensed and Insured. Over 20 years experience. Contact Peter 484-350-2205 or psschreier@gmail.com PA#084327

**SERVICES**  
**G.J.Y. EXCAVATING LLC** Septic Systems (new/repairs), Additions, Utilities, Probes, Stone/ Sand Delivery, Demolitions, Brush Mowing, Patios, Land Clearing, Site work, Commercial and Residential. Insured. George 610-587-0885.  
**TREE WORK DONE** Professionally Since 1956. Free Estimates. Equipped with Chipper, Bucket truck, Full Insurance. Call Dale Glenn, 610-756-6062.

**MEN'S HAIRCUTS**  
 \$8.00 Haircuts by Steve  
 610-682-2262  
 Hours: Mon. thru Fri. 8:30 A.M. - 6 P.M. Sat. 9 A.M. - 2 P.M. Call For Appointment  
 16 N. Home Ave. Topton, Pa.

**Bruce W. Obyle T/A WERLEY ELECTRIC LLC**  
 Home, Farm and Business  
 2773 Golden Key Road, New Tripoli, PA 18066  
 Bruce Obyle, Electrician/Owner #PA105730 We Accept Visa, Mastercard & Discover E-mail: werley54@aol.com 610-657-1299 Over 40 Years Experience  
**24-Hour Emergency Service** **FREE Estimates** **Bucket Truck Available**  
 Call us for all your electrical needs.  
 When it comes to your safety and comfort - no job is too small.

**PROPERTY CLEANUP:** We clean attics, garages, basements, brush piles, yard waste and scrap metals, we demo sheds, patio, concrete, fences, large and small buildings etc. along with lot clearing, stump removal and general excavation, small jobs are Our Specialty! Call JOHN HEFFNER 610-587-2886.  
**Maiden Creek Marine** custom boat covers made on site, covers, bow covers, cockpit covers, repairs Quality work, 28 yrs experience. We know what boaters need and expect 610-944-9994.

**REIKI:** The Healing Touch Serving Berks County since 2000. Experience Mind, Body and Spiritual Wellness session of this Holistic/ Alternative therapy by appointment. Holiday Gift certificates available by Reiki Master Teacher Frances Moise. Certified in Usui Shiki Ryoho and Shamballa Multidimensional Healing. Contact: franmoise@comcast.net 610-413-9137.  
**RV MOBILE REPAIR:** Time to get your camper ready for winter! Will winterize at your location and close campers for winter. 610-823-5058.

**Countywide Appraisal Services, LLC**  
**John L. Rothermel, Jr.**  
 PA Certified Residential Appraiser  
 PA Certified Broker Appraiser  
 Berks, Schuylkill and Lehigh Counties  
 Estates, Tax Assessment Appeals, Divorce, Litigation Support, Multi-units, Student Housing  
 13 Pheasant Run Rd., Fleetwood, PA 19522 610-944-6331 countywd@ptd.net Fax: 610-944-6305

**Halys's Automotive** **Complete Auto Service** **Keeping Your Car On The Road!!**  
 • privately owned and operated  
 • personal service every time  
 • complete auto repair brakes, shocks, exhaust  
 • now offering towing  
**Best State Inspection Price In Town only \$33.95**  
**\$10.00 Off ANY PURCHASE OVER \$100** **\$20.00 Off ANY PURCHASE OVER \$200** **\$30.00 Off ANY PURCHASE OVER \$300**  
 HALY'S AUTOMOTIVE Maxatawny • 610-683-6707 Excludes Tires And Batteries. Must present coupon. Not valid with any other offers. Offer expires November 8, 2016. WP  
**\$5.00 Off Any Synthetic Oil Change**  
 AMS Oil or Pennzoil  
 HALY'S AUTOMOTIVE Maxatawny • 610-683-6707 Must present coupon. Not valid with any other offer. Offer expires November 8, 2016. WP  
 15801 Kutztown Road • Rt. 222, Maxatawny, PA 19538 610-683-6707 Mon. - Fri. 7:30 to 5:30; Sat. 8:00 to 12:00



**Strohl**  
AUTOMOTIVE SERVICES  
& PRE-OWNED SALES

**OUR SERVICE DEPARTMENT IS OPEN EVERY SATURDAY Until 1 PM.**

Thanks To All Our Customers For 95 Great Years.

**'14 Honda CR-V AWD EX-L**

Stk. #3470  
Kona Coffee Met., Carfax 1 Owner, 2.4L I4, Auto, 5 Spd., Power Sun/Moonroof, Heated Pwr. Leather Bucket Seats, Backup Camera, Alloy Whls., Bluetooth with Input Jack, and a Lot More. Balance of Honda Warranty, ONLY 35,540 Miles.

**WAS \$23,900**  
**Sale \$21,460**

**95th Year SPECIAL PRICE**

**'07 Jeep Wrangler Unlimited Sahara**

Stk. #3474  
Gray, 3.8L V6, 4 Spd. Auto., Local Trade, Removable Roof Panels, Alloy Whls., ABS w/Stability Control, Side Airbags, Pwr. Options, Extra Soft Top & More, 118,620 Mi.

**WAS \$18,400**  
**Sale \$16,460**

**95th Year SPECIAL PRICE**

**'11 GMC Acadia SLE**

Stk. #3471  
Summit White, 3.6L V6, 8 Pass. with Split Folding Middle & Rear Seats, Front & Rear AC & Heat, Pwr. Options, Remote Start, Alloy Whls., Clean Carfax & Much More, ONLY 59,000 Mi.

**WAS \$19,900**  
**Sale \$17,460**

**95th Year SPECIAL PRICE**

- '00 Pontiac Grand Am SE ..... Reg. \$3,800 - Sale **\$3,340**  
Stk. #3486, Redfire Met., 2.4L 4 Cyl., Auto., Air Cond., 112,600 Miles.
- '05 Mazda Mazda3 S ..... Sale **\$6,400**  
Stk. #3508, Black Mica, 72,700 Mi.
- '95 Chevy Impala SS ..... Sale **\$6,420**  
Stk. #141622, Black Rose Met., 145,500 Miles.
- '07 Chevy Cobalt SS ..... Reg. \$8,800 - Sale **\$6,970**  
Stk. #3468, Laser Blue Met., 2.4L 4 Spd. Auto., Alloy Whls., Pwr. Options, Heated Leather Seats, Rear Spoiler, Pioneer CD/XM with iPod Jack, 76,425 Mi.
- '11 Chevy Cruze ..... Reg. \$8,400 - Sale **\$7,930**  
Stk. #3490, Silver Ice Met., Alloy Whls., Pwr. Options, Side & Curtain Airbags, ABS, 77,675 Miles.
- '06 Jeep Liberty Sport 4WD ..... Sale **\$8,900**  
Stk. #3506, Deep Beryl Green Pearlcoat, 3.7L V6, Auto., Pwr. Options, Alloy Whls., Local Trade, 119,300 Mi.
- '08 Dodge Caliber AWD R/T ..... **\$8,900**  
Stk. #3505, Surf Blue Pearlcoat, 93,495 Mi.
- '10 Volkswagen Passat Komfort ..... Reg. \$10,400 - Sale **\$9,825**  
Stk. #3491, Deep Black Met., 76,487 Miles.
- '08 Chevy Silverado 2 Dr. 1500 ..... Reg. \$10,900 - Sale **\$10,520**  
Stk. #3501, Dark Cherry Met., 8' Long Bed, 4.3L V6, Auto., 85,400 Miles.
- '11 Chevy HHR LT ..... Reg. \$10,900 - Sale **\$10,520**  
Stk. #3502, Imperial Blue Met., Pwr. Options, 88,600 Miles.
- '13 Hyundai Elantra GLS ..... Reg. \$12,200 - Sale **\$11,725**  
Stk. #3492, Red Allure, 45,790 Miles.
- '11 Ford Escape XLT 4WD ..... Reg. \$13,900 - Sale **\$13,420**  
Stk. #3497, Oxford White, V6, Pwr. Options, Alloy Whls. & Lots More, 71,288 Miles.
- '11 Chevy Cruze LTZ ..... Sale **\$13,900**  
Stk. #3514, Taupe Gray Met., 32,620 Mi.
- '11 Ford Taurus SE ..... Was \$15,400 - Sale **\$13,945**  
Stk. #3478, White Suede, 28,990 Mi.
- '13 Hyundai Sonata GLS ..... Sale **\$14,800**  
Stk. #3510, Indigo Night, 29,054 Mi.
- '06 Chevy Silverado 1500 LS 4x4 Ext. ..... **\$15,800**  
Stk. #3504, Sport Red Met., 5.3L V8, Z71 Pkg., Alloy Whls., Pwr. Options, Trailer Pkg., Locking Differential, 6 Pass., 95,370 Mi.
- '12 Subaru Outback AWD 2.5i ..... Sale **\$16,400**  
Stk. #3509, Cypress Green Pearl, Premium Pkg., Local Trade, 67,500 Mi.
- '13 Ford Escape SE 4x4 ..... Reg. \$17,600 - Sale **\$16,920**  
Stk. #3495, Sterling Gray Met., 46,581 Miles.
- '12 Chevy Express Cargo 2500 ..... Sale **\$19,800**  
Stk. #3515, Summit White 65,160 Mi.
- '11 Jeep Grand Cherokee Laredo 4x4 ..... Reg. \$20,900 - Sale **\$19,930**  
Stk. #3493, White Gold Met., 59,750 Miles.
- '15 Dodge Grand Caravan SXT ..... Sale **\$20,800**  
Stk. #3511, Granite Crystal Met., 28,370 Mi.
- '15 Chevy Equinox LT AWD ..... Reg. \$21,500 - Sale **\$20,920**  
Stk. #F6289418, Blue Velvet Met., Pwr. Seat, Pwr. Options, Backup Camera, Alloy Whls., Side & Curtain Airbags, 44,700 Miles.
- '11 Chevy Silverado 1500 LT EXT CAB 4x4 ..... Was \$26,400 - Sale **\$24,450**  
Stk. #3477, Silver Birch Met., 5.3L V8, AT, 6 Spd., Alloy Whls., Locking Differential, Trlr. Pkg., Pwr. Seat, Pwr. Options & More, 52,325 Mi.
- '12 Dodge RAM ST Crewcab 4x4 ..... Reg. \$25,700 - Sale **\$25,220**  
Stk. #3503, Deep Cherry Red Crystal Pearlcoat, 5.7L V8, Auto., 20" Chrome Whls., Pwr. Options, Bed Liner & Lots More, 55,700 Miles.
- '16 Chevy Impala LT ..... **Just In**  
Stk. #3515, Silver Ice Met., 31,550 Mi.
- '13 Honda Civic LX ..... **Just In**  
Stk. #3516, Crimson Pearl, 32,855 Mi.

**MIGHTY MAC**

- Leaf Shredder-Chippers
- Hammermill Shredder-Chippers

Reduce leaf mass, bag if desired. Chip branches into mulch for attractive bedding.

Bring in a sample of your yard debris and demo a Mighty Mac today!



**GO Green! • GO Organic! • GO Mighty Mac!**

**CANNS-BILCO**  
OUTDOOR POWER EQUIPMENT

125 E PENN AVE ALBURTIS PA 18011  
**610-966-2001**  
www.canns-bilco.com

**SERVICES**

UPHOLSTERY WORK DONE: Furniture, Car & Truck Seats, Replace foam in cushions, Recover Boat Seats, Make Custom Boat Covers, Restring Day & Night Shades, Restaurant Seats and Misc. Items. Call John Stetzler Upholstering, Hours 8-5 610-488-7760, Cell # 484-955-2436. 2485 Shartlesville Rd. Mohrsville. See our website at jjsupholstering.com.

SEAMLESS GUTTERS AND DOWNSPOUTS. Will make and assemble on job site. Additional hardware available. 27 Years Experience. K.W. Greenawalt, 610-298-3380.

**SERVICES**

THE TOPTON PLUMBERS, 109 East High St., Tipton Pa. 19562. Plumbing, Heating, and Electrical Services. Plumbing Repairs. Replacement electric and gas hot water heaters. Gas and Oil Boilers and Furnaces. Drain cleaning, kitchen and bath remodeling. Master Plumber #193. Fully Insured. Call 610-641-7028.

YOUR WORK HARD for your money! We do too! High Quality Repairs at Reasonable Prices. Roofing, Carpentry, Painting, Decks. Call **DIAMOND QUALITY CONSTRUCTION** Today for a Free Estimate, 610-967-1283.

**DEAN R. ARNER, AUCTIONEER, LLC**  
**PUBLIC ESTATE AUCTION**  
Tuesday, November 1, 2016 at 11:00 AM  
Location: 382 Long Lane, Walnutport PA 18088.  
Vintage Funland pinball mach., American Shuffleboard & Co. shuffleboard, asst. vintage games, vintage beer advt. clocks, antiques, old clocks, furniture, tool boxes, tools, Case & Craftsman riding mowers & much more! Check full listing & photos @ www.auctionzip.com ID# 21038.  
**DEAN R. ARNER AUCTIONEER, LLC**  
AY-002077L • Ph.: 570-386-3389

**DEAN R. ARNER, AUCTIONEER, LLC**  
**PUBLIC ESTATE AUCTION**  
Sunday, October 30, 2016 at 10:00 AM  
Location: Andreas Station House, 42 Andreas Rd., Andreas, PA 18211.  
Super nice quality modern furniture, like new DR Set, lg. Thomasville entertainment center, sofas, end & coffee tables, quality household goods, collectibles, tools and much more!  
Check full listing & photos @ www.auctionzip.com ID# 21038.  
**DEAN R. ARNER AUCTIONEER, LLC**  
AY-002077L • Ph.: 570-386-3389

**SERVICE COUPON**  
**AIR CONDITIONING SERVICE**  
**\$10.00 Off**  
Reg. \$59.95 (Check Pressures & Operations. Refrigerant Extra.)  
Good at Strohl Automotive  
Limit One Coupon Per Visit Please WP

**SERVICE COUPON**  
**4-WHEEL ALIGNMENT**  
**\$79.95**  
Reg. \$99.95  
Good at Strohl Automotive  
Limit One Coupon Per Visit Please WP

Many of our vehicles are CarFax 1-Owners and you can get your FREE COMPLETE CarFax report here or on our website.

**Top \$ For Your Trade**

**WE BUY CARS & TRUCKS**

**"Downtown" Fogelsville**  
**610-395-3345**  
**www.StrohlAutos.net**

CARFAX VEHICLE HISTORY REPORTS  
ACDelco  
NAPA AUTOCARE CENTER  
Ford POWER STROKE DIESEL Service & Repair  
AAA Approved Auto Repair  
U-HAUL Hitches

**Help Wanted**  
**GRAPHIC DESIGN**



**Part-Time, Entry-Level Position**

Should be proficient in the following:

- Adobe InDesign, Illustrator, Photoshop, Acrobat
- Word • Excel • Powerpoint

Web Design & Knowledge of QuarkXPress a Plus!

Send Resume to:  
6 North Third Street  
P.O. Box 465, Hamburg, PA 19526-0465  
610.562.2267 or 1.800.562.5521  
display@windsorpress.com  
www.windsorpress.com

**The Windsor Press**  
INCORPORATED

**SERVICES**

Looking to assist Senior Citizens: Retired Certified Medical Assistant looking to earn extra income assisting Senior Citizens in the Macungie, Emmaus, Tipton area with scheduling and transportation to and from doctor appointments, light grocery shopping, assistance with light household duties, pharmacy assistance ie; dropping off and picking up prescriptions and to help with unscheduled emergency transportation needs. I am available M-F, with flexible hours between 8am-2pm. I have valid driver's license and reliable transportation. Hourly rate is negotiable. 610-207-2301.

**PROPERTY CLEANOUTS**  
low rates. Also TV and appliance removal \$25. Call 610-921-5474.

**BUY ★ SELL ★ TRADE**  
Tel.: 610-398-2650

**EAGLE ARMS**  
9331 Hamilton Blvd. (Rt. 222)  
Breinigsville, PA 18031  
www.eaglearms.com

HOURS:  
Mon. thru Fri. 10:30 to 5;  
Sat. 10 to 4;  
Closed Sun.

**Get Quick CASH**

**WANTED!!**

**HANDGUNS**  
**GUN PARTS/BAYONETS/SWORDS**  
**MILITARIA/ARMY SURPLUS**  
**ALL FIREARMS/AMMO**  
**RELOADING SUPPLIES**



**RENNINGERS**  
KUTZTOWN  
740 Noble St. Kutztown, Pa  
610-683-6848  
www.renningers.net

**Farmers Market**  
Fridays 10 to 7  
Saturdays 8 to 4  
**Antiques & Vintage Market**  
Saturdays 8 to 4.  
**Outdoor Flea Market**  
Saturdays at 7 am



Visit the  
consignment  
area.  
Fresh  
merchandise  
every week.

**Jim NEIDERMYER** *peti*  
PHONE: 610-683-6658  
www.jnpoultry.com

(Reg. \$5.49 lb.)  
**HONEY BBQ CHICKEN BREAST** ... SALE lb. **\$4.99**  
(Reg. \$5.49 lb.) **YELLOW & WHITE**  
**CLEARFIELD AMERICAN** ... SALE lb. **\$4.49**  
**APPLEWOOD SMOKED OR PEPPER BACON**  
**YOUR CHOICE OF BACON** ... lb. **\$6.29**  
**HOT HORSE RADISH, SWEET HOMESTYLE, HOMESTYLE**  
**CHECK OUT OUR LINE OF MUSTARD** . jar **\$3.50**

**\*10% OFF**  
FOR ALL ACTIVE & FORMER MILITARY MEMBERS  
\*Not Valid On Bulk Discounts  
VISIT OUR WEBSITE FOR SPECIALS [www.jnpoultry.com](http://www.jnpoultry.com)

**Jim NEIDERMYER** PHONE: 610-683-6658

**Now Taking Thanksgiving Orders**  
**DUCKS • GEESSE • CAPONS • TURKEYS**  
**TURKEY BREAST • SMOKED TURKEY BREAST**  
**& WHOLE SMOKED TURKEYS**  
**ALL NATURAL NO PRESERVATIVES**  
**SINCE 1934**

**\*10% OFF**  
FOR ALL ACTIVE & FORMER MILITARY MEMBERS  
\*Not Valid On Bulk Discounts  
CHECK OUT OUR WEBSITE FOR ONLINE SPECIALS [www.jnpoultry.com](http://www.jnpoultry.com)

**Jim NEIDERMYER** SALADS PH.: 610-683-6658

(Reg. \$5.49 lb.)  
**SHEPHERD'S PIE** ..... lb. **\$4.89**  
**★ Now Taking Thanksgiving Orders ★**

**\*10% OFF**  
FOR ALL ACTIVE & FORMER MILITARY MEMBERS  
\*Not Valid On Bulk Discounts  
VISIT OUR WEBSITE FOR SPECIALS [www.jnpoultry.com](http://www.jnpoultry.com)

Always **FREE** Samples of  
Barrel Pickles • Hand-Stuffed Olives  
Fresh Sauerkraut • Giardiniera  
Pickled Green Tomatoes • Hot Sauces  
**"NATURAL"**  
Flavored Cream Cheeses  
**PETER PIPERS PICKLE PALACE**

**TJ's SEAFOOD**  
Fresh Seafood Every Week  
**717-471-7376**

**SENSIBLE SNAX**  
NUTS, DRIED FRUIT,  
CRANBERRIES,  
WASABI,  
SEVERAL VARIETIES  
OF TRAIL MIXES

**NANCY'S**  
FRESH & HEALTHY MEDITERRANEAN FOOD  
FRESH BAKED GOODS  
FRESH SALADS - HUMMUS • BEAN  
OLIVE, FRESH TABBOULEH, WILD RICE & MORE  
CHICKEN PARMESAN WRAPS • FRESH BAKED VEGGIE PIZZAS  
BROCCOLI & CHEESE PIES • TURKEY PIES • SPINACH PIES  
VEGETARIAN, VEGAN, GLUTEN FREE & MEAT ITEMS  
VARIETY OF ORGANIC ITEMS FRESH FRUIT SMOOTHIES  
CATERING TO ANY SIZE PARTY - 610-451-1087

**4-Pc. BEDROOM SET**  
QUEEN BED,  
DRESSER, MIRROR  
& CHEST  
**\$799<sup>99</sup>**  
**KUTZTOWN FURNITURE OUTLET**  
LOCATED INSIDE RENNINGERS FARMER'S MARKET  
SAVINGS WORTH WAITING THE WEEKEND FOR  
FRI. 10-7 & SAT. 8-4  
610-683-8001

**THE PRETZEL REVOLUTION**  
STUFFED PRETZEL ROLLS  
BREAKFAST  
Bacon, Egg & Cheese  
Sausage, Egg & Cheese  
LUNCH  
• Cheese Steak • Buffalo Chicken  
• Ham & Cheese  
• Italian • Pizza • Hot Dog  
~ THIS WEEK'S SPECIAL ~  
**TURKEY & SWISS**  
w/HONEY MUSTARD

**AVON SALES**  
**DOLLAR SALES**

**BIB-A-LOT**  
FALL KITCHEN TOWELS, MEN'S APRONS,  
RUNNERS, PLACEMATS,  
WALKER CADDIES, ADULT &  
CHILD BIBS, CLOTHESPIN BAGS  
& HOLIDAY ITEMS.  
NEW PATTERNS ARE HERE

**CHRISTMAS OPEN HOUSE**  
November 3, 4, 5 & 6, 2016  
Thurs. 6pm to 9pm - Shopping by Candlelight  
Fri. 10am to 7 pm - Sat. 8 am to 4 pm - Sun. 11am to 4 pm

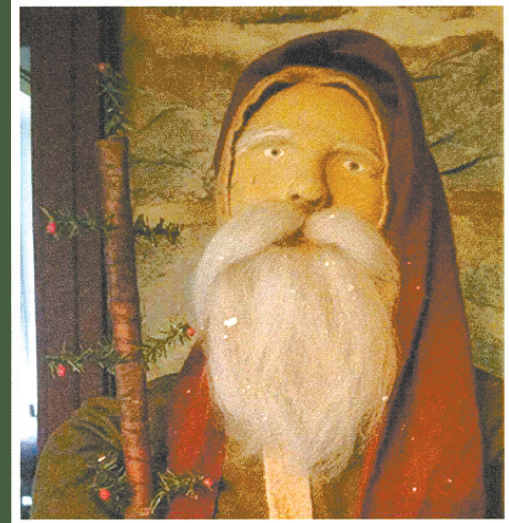

**SHARON RENNINGER'S**  
**COUNTRY MEADOWS**  
740 Noble St., Kutztown, Pa. 19530  
610-683-8307  
sharonrenningersgatherings.com  
facebook.com/sharonrenningersgatherings

**Established Train & Toy Store**  
We Buy - Refurbish - Resell - Repair  
All Makes - Prewar - Post War - Modern  
Std -0-027-HO-N & S Gauge Trains • Accessories • Toys  
Collectibles - Saturdays 8 to 4 Booth D20, 21, 22  
Matchbox, HotWheels, Lead Soldiers, Planes  
Tanks, Cars, Model Kits, Plasticville

**Dietrich's Country Meats**  
610-756-6344

**SAUSAGE SPECIAL**  
Fresh Country • Garlic  
Italian Sweet or Hot  
**5 lbs. \$21<sup>50</sup>**  
WITH COUPON  
EXPIRES 11-3-16 wp

**CENTER-CUT PORK CHOPS**  
Only **\$4<sup>29</sup>** lb.  
WITH COUPON  
EXPIRES 11-3-16 wp

**Dealer Space**  
**Now Available In**  
**Antiques Market.**  
**Apply In Person**  
**Friday or Saturday**  
**Call 610-683-6848.**

**LINDA'S**  
SUBS • SOUPS  
& SALADS  
DINE IN OR TAKEOUT

**STOP BY**  
**THE BREAD LADY**  
**SEE**  
**WHAT'S NEW!**

**GREEN ACRES**  
**ORGANIC FARM**  
Certified Organic Since 1996  
BOWERS RD.,  
KUTZTOWN, PA  
610-682-7460

**HOFFMAN'S**  
PORK BUTT ..... lb. **\$1.99**  
PORK  
SIRLOIN CHOPS... lb. **\$2.69**  
**MEATS** PORK  
SIRLOIN ROAST .lb. **\$2.49**  
PH: **\$4.29**  
610-894-9910 RUMP ROAST ..... lb.  
BAKED LIMA BEANS ..... lb. **\$3.39**  
GREAT LAKES  
WHITE AMERICAN CHEESE .lb. **\$2.99**

**Outdoor Flea Market**  
**Saturdays 7 AM**  
Outdoors - \$10.00 - 20' x 25' - 1 Table If Available  
Additional Tables \$3.00 Each  
Pavilions - \$15.00 - 10' x 25' - 2 Tables  
Additional Tables \$3.00 Each  
610-683-6848 To Reserve A Booth  
No Flea Market During Extravaganza  
[www.renningers.com](http://www.renningers.com)

**NOBLE ST. CAFE**  
SOUPS, SALADS,  
WRAPS, PANINIS,  
FLAT BREAD PIZZA  
★ WEEKLY SPECIALS ★

**CUPBOARD SNACKS**  
FULL LINE OF CHIPS,  
PRETZELS & CANDY  
**Now AVAILABLE:**  
**FUDGE**

**Renninger's Markets - Where Small Businesses Start -**  
[www.renningers.com](http://www.renningers.com)  
[facebook.com/renningers](https://facebook.com/renningers) [Facebook.com/renningerskutztown](https://facebook.com/renningerskutztown)

# INVENTORY LIQUIDATION SALE GOING ON NOW! HURRY IN FOR THE BEST SELECTION!



**STORAGE SHEDS, SINGLE & DOUBLE GARAGES,  
SINGLE & TWO STORY BUILDINGS, HORSE BARN,  
CHICKEN COOPS, POLY FURNITURE ALL AT THE LOWEST  
PRICES OF THE YEAR!**

## EASTERN

Building Products  
**14588 Kutztown Road  
Fleetwood, PA 19522**

**610-683-6120**

Hours:  
Monday to Friday 7AM to 5PM  
Saturday 9AM to 2 PM  
CLOSED SUNDAY

Visit us on  
Route 222, South of Kutztown,  
on the web at [ebpsheds.com](http://ebpsheds.com)  
or call 610-683-6120

### SERVICES

Plastic welding repairs: Farm equipment, livestock waterers, construction, auto, atv parts. Most plastics can be welded. Also aluminum, stainless, and mild steel repairs. Call Windsor Spring Welding with any questions. 610-223-6192.

Winter Replacement Specials \$2,897 gas and oil furnaces, \$3,324 gas and oil boilers \$4377 heat pumps. Call, text or email your pictures, [jpworks@ptd.net](mailto:jpworks@ptd.net) 610-597-4810. J.P. Works Over 30yrs. Experience heating and air conditioning. PA#115527.

### SERVICES

Tranquil Touch Therapeutic Massage, Cindy Varner, LMT. Massage, Reflexology, Cranio-Sacral, Ear Coning, Energy Healing, Raindrop Technique w/Young Living Essential Oils, Reiki. New Tripoli area. 610-698-8676, [ckvarner5@yahoo.com](mailto:ckvarner5@yahoo.com) <http://www.massagefromtheheart.com>.

SCREENED ENRICHED TOPSOIL: \$25/ yard plus delivery fee, large quantity discounts; Nice soil for gardens, flowerbeds and lawns, aged mushroom soil available. Call JOHN HEFFNER 610-587-2886.

### SERVICES

JOHN'S HAULING AND REMOVAL. Appliances, pianos, furniture, large screen tv's. Anything big or small. One piece or truckload. Seven days, last minute service. 610-454-1449.

STUART BROOKS Excavating. 40 Yrs. Of experience. PA 015932. Commercial & Residential Excavating for New homes & additions. Utility trenching for sewer, water & electric. Driveway maintenance, new stone & regrading. Storm water management, underground collection & dispersal systems. Boulder wall, small & large. Exterior basement water proofing. Lawn regrading & erosion control. Demolition work. Dump truck hauling service for stone, mulch & topsoil. 610-929-8118, 484-955-3447.

TIDY TINA'S cleaning services makes your life easier at an affordable rate. Once a month, bi-weekly or weekly. Call for a no obligation estimate for all your cleaning needs. 484-665-3384.

## Northwestern Lehigh School District SUBSTITUTE TEACHERS

Now Using Aesop

See our website for more info  
[www.nwlehighsd.org](http://www.nwlehighsd.org)



## Are You Dependable And Seeking A New Challenge?

Do you enjoy working with customers in developing their advertising and marketing programs?

The Windsor Press, Inc. may be just the employer for you! Located at 6 North Third Street in Hamburg, PA, we're looking for a full-time employee to join our sales team.

Candidates should be energetic and possess a positive, goal-driven mindset. Prior sales experience is a plus but not necessarily required. We will train the right person! This is a commission-based position with health insurance, paid vacation and short-term disability benefits. This is a Monday through Friday position.

Founded in 1958, The Windsor Press Inc. is a full-service printer and publisher of The East Penn Valley and Northern Berks Merchandisers. We are a privately owned company serving Berks, southern Lehigh and parts of Schuylkill counties for 56 years.

Interested applicants should E-mail their resume to [matt@windsorpress.com](mailto:matt@windsorpress.com). Please feel free to email any questions to the same email address.

We are an equal opportunity employer.



## Rabies Clinic & Low Cost Vaccines

Saturday, October 29 - 11 a.m. to 2 p.m. - Leesport Farmers Market  
(In The Meeting Room) 312 Germants Church Road, Leesport

Sunday, October 30 - 12 p.m. to 3 p.m. - Schuylkill Mall, Rt. 61, Frackville

Call for directions: 484-769-8926

Find All Your Pet's Needs at Adorable Pets in the Leesport Farmers Market on Wednesdays located in Building 3.

Cats and Dogs  
Rabies Shot .....\$18.00 - \$27.00  
Parvo - Distemper (DHLPP) .....\$22.00  
Cat Shots FCRCP .....\$22.00  
Heartworm Check .....\$29.00



www.AdorablePetsOnline.com

NAILS  
CLIPPED  
EAR  
CLEANING  
TEETH  
BRUSHING  
**Clinic  
Special  
\$6.00 each**

### SERVICES

SEWING MACHINE TUNE-UP: We will have your sewing machine humming, looking good. LET'S SEW. Call 610-285-6597. ALTHOUSE'S SEWING CENTER. Fogelsville.

PET CREMATION Services Peach Tree Cremation Services, LLC, Leesport. Call Derek M.D. Leiben-sperger, 610-926-2737. Family Owned & Operated.

### PETS & ANIMALS

FOR SALE: Dog kennel. 4ft wide by 6ft long by 4ft high. \$150 or best offer. Also plastic dog crate 40"long by 26"wide by 30"high. \$60 or best offer. Call 610-689-5279

Kittens and Cats for adoption. Barn cats, Indoor/ outdoor, House Cats & Kittens already neutered PAW-FUR Rescue, Kathy 610-682-2688. For low cost neuter 866-820-2510.

### HELP WANTED

EXPERIENCED fuel oil and propane truck drivers needed. Must have CDL License, Class B with X endorsement. Call 610-488-1720.

Part Time Warehouse: Day assignments in Breinigsville. 8:30p-5:30a. \$15/hr, unloading trucks. Call Today! 610-432-4161. [www.htss-inc.com](http://www.htss-inc.com)

## Propane Delivery To Your Home

Call Now To Place Your Order!

Deliveries Are Done Within  
2-3 Business Days, No Hassle...  
We Accept All Credit Cards. Call Us!



A Local Family-Owned Business  
610-916-0237

[www.elitefuelservice.com](http://www.elitefuelservice.com)

READING, PA 19605 HIC# PA017944

**SERVING BERKS COUNTY**

TREE REMOVAL, Stump Grinding and Pruning By "King, At Your Service", a Local Father-Son Operation. For Free Estimate, [kingatyourservice.com](http://kingatyourservice.com) or Call Bradley at 610-756-6024. Fully Insured!

### PETS & ANIMALS

D AND D KENNEL, Full service pet grooming and boarding with luxury bedding, heated floors, private patio. Dog rates start at \$20, also daycare. <http://danddkennel.webs.com/> 610-944-6468.

Miniature Long Hair Dachshunds, Ready Now, \$300; 610-413-5543.

LISA'S PROFESSIONAL PET GROOMING: 20 Years Experience. Specializing in small & large Dog breeds. Reasonable Rates. AM & PM hours available by appointment. 32 Hill Rd., Fleetwood, 610-987-3860.

MUTH KENNELS: Boarding Dogs. Will take dogs out to Walk & Play. Lots of Love. \$22 a Day. Two Dogs \$21 a day each. Bring Own Food. 610-395-1816.

### HELP WANTED

Sewers For a small company, sewing different sizes of fabric filter bags. Sewing machine is merrrow, single needle, 3 spools of thread. Fax resume to 610-437-3377 or email [info@miroil.com](mailto:info@miroil.com). You may also apply in person Mon-Fri at Miroil 602 Tacoma St. Allentown, Pa 18109.

## Up To \$70

Visa Prepaid Card\*

With 4 Tires Purchased - Cooper, Mastercraft, General & More

Buy 4 Shocks  
For The Price of 3\*

## Up To \$80

Visa Prepaid Card\*

On Exhaust Systems

\*Thru Oct. 31, 2016

## SMITH'S GARAGE

ONE-STOP SHOP

Monday to Friday  
8:00 a.m. to 5:30 p.m.  
Saturdays by appt.

Since 1980  
610.395.6963

## Now Hiring Immediate Openings

### Battery Manufacturer Hiring

Entry Level Production & Warehouse Positions  
Available with Area's Largest Employer

Also Hiring For Many Other Companies Including:  
- Machine Operators - Forklift Operators  
- Food Production / Packing - and more

POSITIONS AVAILABLE ON ALL SHIFTS

Temporary & Temp-Hire Positions  
Starting Pay Rates from \$10.00 - \$15.00/hr+

Apply today at **Champion Personnel**  
Online: [www.championpersonnel.net](http://www.championpersonnel.net)

or at our office located at:  
3607 Pottsville Pike, Reading, PA 19605

Walk-in applications taken from 9:00am - 11:00am Monday thru Friday  
& 1:00am - 3:00pm Monday thru Thursday

or send a resume to  
[resumes@championpersonnel.net](mailto:resumes@championpersonnel.net)



For more info.,  
call 610-927-5221

**SAVINGS BUFFET**

Discount prices on an ever changing buffet of a wide range of items consisting of, but limited to, tools, hardware, outdoor, housewares, toys & bikes.

**NEW MERCHANDISE AT DISCOUNT PRICES**

**10% SURPLUS SALES %**  
By: [www.friendlydutchman.net](http://www.friendlydutchman.net)

NEW GENERAL MERCHANDISE - OVERSTOCK, DISCONTINUED & RETURN GOODS AT DISCOUNT PRICES  
59 Constitution Blvd Kutztown PA 19530 Phone 484-578-9104

Product selection changes constantly  
Visit our store & website often!  
The kind of place you will probably tell your friends about

**HELP WANTED**

**Brewery Associates:** Start immediately! FT, PT and Weekends avail in Fogelsville in bottling/packaging department. No exp. needed. \$12/hr. Call Katie at HTSS: 610-432-4161 ext 16 or apply online at [www.htss-inc.com](http://www.htss-inc.com).

**Buffet Attendant, Hotel** seeking PT Breakfast Attendant. Includes setup and breakdown of buffet. We are looking for an outgoing, organized guest service oriented individual. Please apply within, Staybridge Suites, 327 Star Road, Allentown Pa

**Delivery driver 9am-4pm Mon-Fri.** Please apply in person at Mark's Sandwich Shop, 123 West Main Street, Kutztown, PA 19530 or call 610-683-3626. Ask for Luke or John.

**HELP WANTED**

**Kutztown Area Railroad Construction Company** looking for full time mechanic. Duties include: Repair and maintenance of construction equipment, Heavy trucks, Medium duty trucks, Light trucks and cars, Railway construction equipment. 610-683-7383.

**Local excavating company** looking for qualified CDL Class A or B drivers for local dump truck hauling. Full time benefits include health insurance coverage, paid vacation and holidays. An Equal Opportunity Employer, M/W. Call 610-929-5251.

**Seasonal Openings:** Looking for extra money? Package Handlers positions area available at the brand new FedEx Macungie Warehouse. Flexible shifts. November-January. \$12.10/hr. No exp. Necessary! Call today: 610-432-4161.

**Production Associates:** FT. Kutztown. \$11-\$13/hr. 2nd & 3rd shifts. Call Lori at HTSS: 610-432-4161. [www.htss-inc.com](http://www.htss-inc.com)

**Help Wanted:** Local business needs a part time office and sales assistant. Must be friendly, personable and dependable. Call 610-683-7324.

**Remember To Buckle Up And See Us For Your Insurance Needs!**

**THE RHODE AGENCY, INC.**  
INSURANCE  
KUTZTOWN  
252 W. Main St.  
610-683-3565  
[www.rhodeagency.com](http://www.rhodeagency.com)

**HELP WANTED**

**Help needed:** HVAC Technician. Heating & Cooling. Please send resumes to Francis L Werley Inc P O Box 206 Hamburg Pa 19526 or call 610-562-2236 ask for Dwight or Ryan.

We are an online vinyl graphics business located in Port Clinton, PA and are looking to fill two positions; customer service and vinyl transfer taper. The Customer Service position will consist of taking down orders through email. The Transfer Tape position includes peeling and transfer taping the orders. Both positions are open to either full or part time. If you are interested in either position and would like to set up a quick interview, please email [1060graphics@gmail.com](mailto:1060graphics@gmail.com)

**Prep Cook, line Cook, Sautee Cook, Dishwashers & Banquet Servers.** Stop in for application or visit [www.folinoestate.com](http://www.folinoestate.com) Join or team. Folino Estate, 340 Old Rt. 22, Kutztown. 484-452-3633.

**OPEN HOUSE**

**Saturday, November 5  
8 am to 2 pm**

**20% Off PARTS**



**Raffle & Drawing  
Free Refreshments**



**Kermit K. Kistler, Inc.**

7886 Kings Hwy/Route 143, New Tripoli, PA 18066  
610-298-2011 | [www.kermitkistler.com](http://www.kermitkistler.com) | [kinc@ptd.net](mailto:kinc@ptd.net)  
Hours: Mon. - Fri. 8 am to 5 pm; Sat. 8 am to 12 pm



**E-Z Weelz Auto Sales**  
610-841-5670  
OR 484-951-4011  
7831 Main St., Fogelsville, PA 18051  
[www.ezweelzautosales.com](http://www.ezweelzautosales.com)

**BUY HERE... PAY HERE! DRIVE TODAY!**

Ask About Our **Credit Approval** **Guaranteed**

- 2006 Chevy Cobalt 4 Dr., 5 Spd. \$1,988
- 2000 Saturn SC1 2 Dr., 5 Spd. \$2,488
- 2000 Chrys. Cirrus 4 Dr. \$2,988
- 2001 Ford Taurus SE \$2,988
- 2003 Chevy Malibu LS 4 Dr. \$3,488
- 2003 Saturn Ion 5 Spd. \$3,988
- 2007 Pontiac G5 2 Dr. Auto. \$4,988
- 2005 Ford Focus SE FX4 4 Dr., Auto. \$5,488
- 2005 VW Jetta GLS \$5,988
- 2007 Pontiac G6 4 Dr. One Owner. \$6,988
- 2004 Lincoln Town Car Signature One Owner!
- 2006 Nissan Sentra 1.8S One Owner. Like New!

**TRUCKS, VANS, SUVS**

- 1995 Ford Windstar Low Miles, Very Nice. \$2,488
- 2001 Ford Windstar SE \$2,788
- 2003 Nissan X-Terra 4x4 SUV, One Owner \$3,988
- 2002 Ford Explorer XLT 4x4, 3rd Row Seat \$5,988
- 2003 Ford Explorer XLT 4x4, 3rd Row Seat \$5,988
- 2005 Dodge Caravan 7 Pass., DVD \$5,988
- 2005 Jeep Grand Cherokee Laredo, V8, Sunroof. \$7,988
- 2006 GMC 1500 SLE Crew Cab 4x \$11,988
- 2000 Ford F150 XLT Reg. Cab Pickup 8' Bed, 6 Cyl., 5 Spd., AC, w/Cap. Only 78K Mi.!
- 2005 GMC Sierra 1500 Ext. Cab, 4x4, Pickup. One Owner!
- 2007 Dodge Ram 1500 Laramie, Quad Cab, 4x4. One Owner!

**Strohl**  
AUTOMOTIVE SERVICES & PRE-OWNED SALES  
"Downtown" Fogelsville  
**WE BUY CARS & TRUCKS**

**FOLINO ESTATE**  
VINEYARD & WINERY  
*Nel Vno Ce la Verita*  
[EST. 2014]

**NOW HIRING!**  
Prep Cook, Line Cook, Sauté Cook  
Dishwashers, Banquet Servers

Stop In and Pick Up An Application  
or [www.folinoestate.com](http://www.folinoestate.com)

**JOIN OUR TEAM!**

[www.FolinoEstate.com](http://www.FolinoEstate.com)  
484-452-3633 | 340 Old Route 22, Kutztown, PA 19530

**HELP WANTED**

**TOWING COMPANY** Looking for tow truck operators, FT/ PT needed, experience a plus, clean driving record and criminal background required. Apply in person at Always Towing 5 Pinedale Industrial Rd Orwigsburg.

**Machine Operators:** Fogelsville bottling company is hiring full time associates. 7a-7p: \$13.59/hr or 7p-7a: \$14.58/hr with increases up to \$19/hr. No exp. necessary. Company will train. Call Arlyce at HTSS: 610-432-4161, ext. 33. [www.htss-inc.com](http://www.htss-inc.com)

**Pickers/ Packers:** Full time. Alburts area. 1st & 2nd shifts available. \$11-\$11.50/hr + \$1/hr bonus for attendance. Call Arlyce at HTSS: 610-432-4161 ext 33. [www.htss-inc.com](http://www.htss-inc.com)

**HELP WANTED**

**WAREHOUSE:** Order Pickers, Packers and Material Handler, light lifting, \$8.50 hr., days, seasonal help until the holidays. Gifts 'N Things, 145 Highland Ave., Kutztown. PA 19530 610-944-1400.

Visit Our Website At: [www.windsorpress.com](http://www.windsorpress.com)

**Say You Saw It In**  
The East Penn Valley  
*Merchandise*

**Help Wanted Lead Carpenter** Stanley W. Bauman, Jr. General Contractor, Inc.

Roofing, Siding, Windows, Concrete, General Carpentry  
Must have hand tools. Valid PA Driver's license is required.  
Apply at 17 E. Franklin Street, Topton, PA 19562

**SW Bauman** G.C., Inc.  
[info@swbauman.com](mailto:info@swbauman.com) Phone 610-682-7124 Fax 610-682-2581  
Equal opportunity employer  
HIC Registration #5459  
Web: [www.swbauman.com/employment.htm](http://www.swbauman.com/employment.htm)

**NOW HIRING LABORERS**

**Start Your Career In Metal Building Construction**

Tools and training provided.  
Competitive Wages,  
Advancement Program and Benefits.

Please Apply In Person or online

**S&S STRUCTURES, INC.**  
536 Blandon Rd., Rt. 73, Fleetwood, PA 19522  
610-944-9956 • [www.ssstructures.net](http://www.ssstructures.net)

**CARRIER NEEDED TO DELIVER**  
THE EAST PENN VALLEY  
*Merchandise*

**Walking Route: EMMAUS**

**Must Be Dependable!**  
Once A Week Delivery, No Exceptions.

Call **Casey Maurer**  
610.966.9557

Shopping in a Winter Wonderland...



# 2016 Winter Fun and Shopping Guide

Featuring...

## WINTER ACTIVITIES, GIFT IDEAS & COUPONS

Your ad will appear in the November 16<sup>th</sup> editions of **BOTH** the East Penn Valley and Northern Berks *Merchandisers*

OPTIONS:

Full Page: \$840 **Save \$266!** 1/4 Page: \$210 **Save \$263!**  
1/2 Page: \$420 **Save \$292!** 1/8 Page: \$105 **Save \$187!**

To place your ad in this exciting edition or for more information, contact your sales representative or our office at:



6 North Third Street  
P.O. Box 465  
Hamburg, PA 19526-0465  
610.562.2267 or 1.800.562.5521  
FAX: 610.562.2770  
display@windsorpress.com  
www.windsorpress.com  
Hours: Monday - Friday 8am to 5pm

**DEADLINE:**  
Tuesday,  
Oct. 25, 2016

**ONE PRICE! Full Color & Both Merchandisers!**  
**SAVE up to \$292**

**TIME TO ADVERTISE IN THIS POPULAR HOLIDAY GUIDE!**

# OUT ON THE TOWN

**DEUTSCH ECK**  
(DUTCH CORNER)

HOURS:  
Wed., Thurs. & Fri. 4 PM-8 PM;  
Sat. 11:30 AM-8 PM;  
Sun. 11:30 AM-7 PM  
Closed Mondays & Tuesdays

Sandwiches  
Platters  
Homemade Desserts  
STEVE STETZLER, Owner

LENHARTSVILLE, PA • 610-562-8520

**THIS WEEK** Oct. 26, 27 & 28 **Pig Stomach**  
**NEXT WEEK** Nov. 2, 3 & 4 **Corn Pie**  
Nov. 9, 10 & 11 **Chicken Pot Pie**  
Nov. 16, 17 & 18 **Chicken & Waffles**  
*Seconds On Us, While Quantities Last!*

**Thanksgiving Pie List on The-Eck.com**

**Alburtis Rod & Gun Club**  
610-966-5733

**HALLOWEEN DANCE**  
**Sat., Oct. 29**  
Music By "Turn Row"  
8 p.m. to Midnight  
A Covered Dish Will Be Held For Those Who Wish To Participate  
★ Costumes Are Optional ★  
**Coming Event: Turkey Shoot**  
**Sun., Nov. 13**

**VIRGINVILLEHOTEL.COM**  
**610-562-7072**

NEW HOURS:  
Wednesday to Friday Open at 4:00 p.m.;  
Saturday & Sunday Open at 12:00 p.m.

**SERVING REAL FOOD FOR REAL PEOPLE**

Visit Our Website For Menu  
www.virginvillehotel.com

Located In The Village Of Virginville Rt. 143  
Just 10 Minutes From I-78 or Rt. 222

- WEDNESDAY SPECIAL -**  
STEAK & SHRIMP \$18.50  
8 oz. NY STRIP & 1/2 LB. STEAMED SHRIMP
- THURSDAY SPECIAL -**  
BUILD YOUR OWN BURGER \$6.50
- SUNDAY SPECIAL 12-5 PM -**  
All-You-Can-Eat PAN-FRIED FISH with 2 sides \$13.50
- WEEKEND SPECIALS -**  
STEAK & SHRIMP SCAMPI  
CHICKEN PICCATA  
PORK & SAUERKRAUT

**4th Annual BAILEY WOOD PRODUCTS**

**Woodworker's FAIR**

**FREE ADMISSION RAIN or SHINE**  
October 29 & 30  
10 a.m. to 4 p.m.

Woodworker's Booths - Christmas Shopping  
Demonstrations - Vendors - Crafts - Food

Bailey Wood Products, 441 Mountain Road, Kempton, PA 19529 - www.baileywp.com - 610-756-6827

**FREE RAFFLE TICKET** No Cash Value Code: Merchandiser  
2016 Woodworker's Fair

Name: \_\_\_\_\_ 1st Prize: Large Custom Cutting Board  
Email: \_\_\_\_\_ 2nd Prize: Wood Species Sample Pack  
Ph: \_\_\_\_\_ 3rd Prize: \$25.00 Gift Certificate

One per person - No need to be present at drawing - Prize must be picked up

**BAILEY Wood Products**  
Kiln Dried Hardwoods and Millwork

# new BAR HOURS

**Live music every Friday & Saturday evening!**

**at the CI Hamburg Super-Store**  
**MONDAY-THURSDAY 11AM-12AM**  
**FRIDAY-SATURDAY 10AM-2AM**  
**SUNDAY 10AM-7PM**

Like us on Facebook for happy hour specials!

1635 Mountain Road • Hamburg, PA 19526 • 610-562-0500

**CIGARS INTERNATIONAL**  
EST. 1998

**LYONS FIRE Co. #1**

**Halloween Bash**  
October 28, 2016

Music by "TURN ROW" 9 pm - 1 am  
Costume Prizes & Door Prizes Awarded  
Snacks Available

9 Centre Avenue  
**TOPTON**  
610-682-4447

New Hours:  
Mon. - Fri. 5:30 am to 2 pm  
and 4:00 pm to 8:00 pm;  
Sat. 5:30 am till 12 noon;  
Sun. 7:30 am till 12 noon

**JAK'S** Prop. Jeff Ponce  
**DOWNTOWN DINER**

*This Week's Specials*

TUES.	SALISBURY STEAK (Incl. 2 Veggies.)	\$6.25
WED.	CHICKEN POT PIE (Incl. 1 Veg.)	\$4.65
THURS.	GRILLED PORK CHOPS (Incl. 2 Veggies.)	\$6.80
FRI.	SEAFOOD SPECIAL	SEE MENU
	BEEF TIPS OVER NOODLES (Incl. 1 Veg.)	\$6.95
MON.	SPAGHETTI & MEATBALL (Incl. 1 Veg.)	\$4.65

~ ALL INCLUDE ROLL & BUTTER ~

**PAPPY T's PUB**

Gift Certificates Available • www.pappyts.com  
Delicious Pub-fare Check Out Our New Menu!  
12 Beers on Tap Your Favorite Cocktails

**~ CHAD'S PAPPY T'S CHEF SPECIALS ~**  
Served Thurs., October 27 to Wed., November 2, 2016

- HOMEMADE SWEET ITALIAN SAUSAGE & SWEET CORN CHOWDER**  
MINI ROASTED PORK CHIMICHANGAS  
(Crispy Mini Flour Tortillas Stuffed w/Our Slow-Roasted Pulled Pork, Caramelized Onions, Jalapeños & Monterey Jack Cheese), Served w/Our Homemade Salsa
- ROASTED TURKEY BREAST OVER BISCUITS w/SAWMILL GRAVY**  
Served w/Homemade Potato Filling & Choice Of Seared Brussels Sprouts Or Buttered Sweet Corn
- CHICKEN & BROCCOLI CHEDDAR ALFREDO**  
Served w/Garlic Breadsticks & Your Choice Of A Side Caesar Or Garden Salad
- BROILED SWORDFISH SCAMPI**  
(Broiled Swordfish Steak Topped w/A Garlic Lemon Butter White Wine Sauce), Served w/Your Choice Of 2 Sides & Homemade Soup Or Garden Salad
- CHOICE 16 Oz. GARLIC-CRUSTED PRIME RIB AU JUS**  
Served w/Your Choice Of 2 Sides & Homemade Soup Or Garden Salad

**DESSERTS - PUMPKIN CHEESECAKE OR GERMAN CHOCOLATE CAKE**

**WEEKLY FOOD SPECIALS**

**DAILY DRINK SPECIALS**  
\$2.00 Well Liquor - All Day! Every Day!

**HAPPY HOUR:** Monday thru Friday 5:00 pm to 7:00 pm  
We Are A Nonsmoking Establishment  
50 Industrial Drive, Hamburg • 610.562.5645  
(Behind The Microtel Inn & Suites - Across From Cabelas)  
OPEN 7 DAYS A WEEK - Bar Hours: Sun. 11 AM till 1 AM;  
Mon. thru Thurs. 3 PM till 2 AM; Fri. & Sat. 11 AM till 2 AM,  
Kitchen - Sun. 11 AM till 10 PM; Mon. thru Thurs. 3 PM till 10 PM; Fri. & Sat. 11 AM till 10 PM

**BIKER FRIENDLY BAR**

**MICROTEL INN & SUITES**  
• Conference Room • Game Room • Jacuzzi Suites  
WIRELESS HIGH SPEED INTERNET

**COUPON**  
**10% OFF Food Purchase**  
PAPPY T'S PUB  
Meals Only. Beverages Not Included.  
Not to be combined with any other discount.  
Coupon good Thurs., Oct. 27 - Wed., Nov. 2, 2016 WP

**ENTERTAINMENT**  
**WED., OCT. 26:** 9:00 pm-12:00 am  
**BIG SHOW KARAOKE w/JIM**  
**THURS., OCT. 27:** 8:00 pm-11:00 pm  
**OPEN MIC w/CHIP**  
**FRI., OCT. 28:** 9:30 pm-12:30 am  
**HALLOWEEN PARTY** - Costume Prizes  
Music By "MONDAY'S MISTRESS"  
**SAT., OCT. 29:**  
**CLOSING AT 5 PM**  
**FOR KING FROST PARADE**  
**TUES., NOV. 1:** 7:30 pm-???

**FREE TEXAS HOLD'EM POKER**

**KUTZTOWN FIRE CO.**

**WEEKEND SPECIALS**  
Friday, Oct. 28, Saturday, Oct. 29 & Sunday, Oct. 30

**Shrimp Lo Mein**  
**Chicken Enchiladas**  
**Beef Bulgogi**

**TACO NIGHT**  
Tuesday, November 1

<b>THURSDAY NIGHT WING NIGHT</b> (6) \$3.50 (12) \$6.50 Best Wings in Town! OVER 20 DIFFERENT FLAVORS	<b>Wednesday All-You-Can-Eat Pasta \$5.50</b>	<b>Friday Special: Lobster Tail Dinner \$16.99</b>	<b>Saturday Special: Black Diamond Steak Dinner \$12.99</b>
--	---	--	---

**WEDNESDAY, NOVEMBER 2 PIZZA & BEER NIGHT**

**PLEASE COME AND JOIN US!**  
The social quarters is open to the public for meals Until 9 pm;  
Open Mon. - Thurs. 4 pm; Fri. 2 pm; Sat. & Sun. 12 pm  
**NONSMOKING 'TIL 10 P.M.**  
(Nonmembers must be signed in by a member to be served alcohol.)  
**610-683-8703 Ext. 3**

# OUT ON THE TOWN

**Fleetwood Volunteer Fire Company #1**  
 Social Quarters  
 101 North Franklin St., Fleetwood, PA 19522  
 610-944-8595

**HOURS:** Tues., Wed., & Thurs. 6pm-close; Fri. 7am-close; Sat. 4pm-close & Sun. 12pm-close  
**FREE POOL HOURS:**  
 Tues. 6pm-9pm; Sat. 4pm-7pm; Sun. 12pm-3pm.  
**OPEN DAY-1st Friday of every month (no member needed)**

<p><b>October 28th HALLOWEEN PARTY</b>                  HyJynx 9pm-12am                  • Raffles, Food, Games, Costume Contest                  Must Be A Member, or Signed In By A Member</p>	<p><b>November 12th KARAOKE</b>                  9pm-12am                  Hosted By DJ W.I.O.</p>
--	--

## Holiday Craft & Vendor Show

Sun., Nov. 6, 9 am to 3 pm  
 Seisholtzville Fire Company  
 24 Saint Peters Rd., Macungie, PA 18062  
 Direct Sales Vendors, Crafters, Raffles, Breakfast & Lunch Menus  
 Partial proceeds go to benefit the Seisholtzville Fire Co.

**FREE SWAG BAGS**  
 Each bag will have 2 FREE Raffle Tickets  
**3 RANDOM BAGS** will have a Gift Certificate good with any vendor.  
 For more information contact Jennifer Smith  
 eventsbyjseventplanning@gmail.com - 267-382-9740

## GATEWAY CHRISTIAN SCHOOL

Annual All-U-Can-Eat **HAM DINNER**

Ham Mashed Potatoes  
 Coleslaw Applesauce  
 Green Beans Roll/Butter  
 Apple or Pumpkin Pie  
 Ice Cream & Beverage

- EVERYONE WELCOME -  
**Saturday, Nov. 5, 2016 from 4-7 p.m.**

**GATEWAY CHRISTIAN SCHOOL**  
 245 Frederickville Rd., Mertztown, PA 19539 • 610-682-2748  
 www.gatewaycs.org • gatewaychristianschool@hotmail.com  
 Adults \$10 • Children 5-11 Years \$5 • 4 Years & Under Free  
 Tickets may be purchased by calling 610-682-2748 or at the door.  
 Takeout is available.  
 ALL PROCEEDS BENEFIT GATEWAY CHRISTIAN SCHOOL

## Fundraiser HALLOWEEN COSTUME PARTY

OLDIES THEME  
 Music By: TOM CALVIN'S OLDIES  
**Sat., October 29, 7-11 pm**

Snacks Provided Nonmembers \$3.00 Charge Reservations Suggested.  
 Contact Wayne: 484-274-1473 or VFW 610-395-2972

**BREINIGSVILLE VFW POST 8282**  
 1522 Butz Road, Breinigsville, PA

Costume & Door Prizes  
 Raffles 50/50 Drawing  
 Must Be 21

## BELLEMAN'S CHURCH Christmas Bazaar

in the Fellowship Hall  
**FRIDAY, NOV. 4, 2016**  
 8:30 a.m. to 7:00 p.m.  
**SATURDAY, NOV. 5, 2016**  
 8:30 a.m. to 1:00 p.m.

3540 Belleman's Church Rd., Mohrsville  
 610.926.4280

- \*Crafts
- \*Pastries
- \*Breakfast, Lunch & Dinner
- \*Homemade Breads
- \*Candy
- \*Homemade Foods Served
- \*Soups \*BBQ
- \*Chicken Pot Pie Platter
- \*Sandwiches & More
- \*Flea Market

## Lyons Fire Company's 5th Annual CHRISTMAS CRAFT SHOW

Saturday, December 3  
 10:00 am to 3:00 pm  
 110 Park Ave., Lyon Station, PA 19536

Free Pictures With Santa  
 Baked Goods ★ Crafters ★ Vendors ★ Raffles

## HOLIDAY BAZAAR

**Kutztown Fire Company**  
 310 Noble St., Kutztown  
**Sun., Nov. 20, 2016 - 10:00 a.m. to 3:00 p.m.**  
 Sponsored by The Ladies' Auxiliary

**HANDMADE CRAFTS** **DIRECT SALES & LOCAL BUSINESSES** **HOLIDAY QUILT RAFFLE**

**Pa. Dutch Kitchen • Holiday Cookies & Desserts**  
**Basket Raffle**  
 FREE ADMISSION. Vendor Info. contact: 484-332-1848

## Fireman's Chicken Pot Pie Dinner

LYONS FIRE COMPANY BANQUET HALL  
**Nov. 6, 2016 11:00 a.m. to 3:00 p.m.**  
 (Takeout Available)  
 All-You-Can-Eat \$8.50 • Children 5 & Under Free  
 Join us for a great meal of Chicken Pot Pie with all the trimmings.  
 Proceeds benefit the Lyons Fire Co. Equipment Fund  
 Keep our trucks rolling and our firefighters safe!

**KUTZTOWN ROD & GUN CLUB** Check us out on Facebook.com

**Monthly Meeting Second Thursday Of Every Month!**

**MONDAY, OCTOBER 24 & WEDNESDAY, OCTOBER 26:**  
**HAPPY HOUR - 5 pm to 7 pm**  
 \$.25 Off All Drinks (Excludes Soda) and **FREE Hot Dogs!**

**TUESDAY, OCTOBER 25 & THURSDAY, OCTOBER 27:**  
**HAPPY HOUR - 2 pm to 4 pm \$.25 Off All Drinks!**  
 (Excludes Soda)

**TUESDAY, OCTOBER 25 & THURSDAY, OCTOBER 27:**  
**FRYER NIGHTS 5 pm to 9 pm**

**FRIDAY, OCTOBER 28 & SATURDAY, OCTOBER 29:**  
**DINNER SPECIAL 5 pm to 9 pm (Including regular dinner menu)**  
**FILLET OF HADDOCK (Pan Fried or Grilled)**  
**COCONUT SHRIMP**

**FRIDAY, OCTOBER 28:**  
**ADULT HALLOWEEN PARTY**  
 Music by "PRETTY VACANT"

## COMEDY NIGHT

Featuring **EARL DAVID REED OF 105.7X**  
**Sat., Nov. 12, 2016 at 8:00 PM**  
**Oley Valley Fair Centre**  
 \$30.00 Per Person  
 Includes: Hot Buffet Dinner, Beer & Soda  
 B.Y.O.B. Is Permitted  
 Doors Open At 6:00 PM - Dinner Served At 6:30 PM  
**Advanced Tickets Needed!**  
 For Tickets/Info. Call: 484-256-8008 or 610-987-6671

## Craft FAIR

**Saturday, Nov. 5, 2016** **9 AM to 2 PM**  
 at **Lower Macungie Fire Dept.**  
 Brookside Rd. In Wescosville  
 Crafts • Homemade Lunch • Bake Sale  
 Chinese Auction  
**FOR INFO: 484.239.3945**

# Did You Know We Print....

# GIFT CERTIFICATES



To place your order... contact:

**The Windsor Press** SINCE 1958  
 INCORPORATED

6 North Third Street,  
 P.O. Box 465  
 Hamburg, PA 19526-0465  
 610-562-2267 or 1-800-562-5521  
 FAX: 610-562-2770  
 E-mail: display@windsorpress.com  
 www.windsorpress.com



# OUT ON THE TOWN

*Come Fly With Us!* **FREE FLIGHT SIMULATOR EXPO**

5 Sim Stations

ReMax Building, 1290 Broadcasting Rd.  
Wyomissing, PA 19610

**SATURDAY NOVEMBER 5, 2016**  
10 am - 8 pm

Sponsored by TruFlights, Inc.  
To reserve flight time, please call 610.682.9764

**LEESPORT FARMERS MARKET**  
EVERY WEDNESDAY  
8 A.M. to 7 P.M.

Flea Market 7:00 A.M.  
Livestock Auction 1:00 P.M.  
8 miles north of Reading, PA  
At the North End of Leesport  
Turn East Off Rt. 61  
610-926-1307  
www.leesportmarket.com

**Wed., Oct. 26**  
*Halloween Treasure Hunt*  
10:00 a.m. to 6:30 p.m.  
(Children 12 & under)

**Parade & Costume Contest**  
5:30 p.m. to 6:30 p.m.  
(See website for details)

**Sun., Nov. 6**  
7:00 a.m. to 1:00 p.m.  
**Flea Market & Toy Show**

Flea Market Every 1st & 3rd  
Sunday thru Dec. 4th

**Dryville Hotel**  
Mon., Tues., Wed. & Thurs. 11am to 9pm  
Fri. 11am to 9:30pm • Sat. 11:30am to 9:30pm

**LUNCH SPECIALS**  
10/24 - COUNTRY FRIED CHICKEN  
10/25 - FISH & CHIPS  
10/26 - HAM BLT  
10/27 - 2 CHILI DOGS  
10/28 - GRILLED RACHEL SANDWICH  
10/31 - CORN PIE

**OCTOBER 27TH, 28TH & 29TH DINNER SPECIALS**  
POT ROAST  
CHICKEN OSCAR  
SCALLOP SCAMPI

**WED., OCT. 26TH**  
**2 for \$22** Complete menu posted on our website

**THURS., OCT. 27TH**  
**CLAM NIGHT**  
SERVING CLAM SPECIALS including our clam bake. See our website for full menu.

**FREE WIFI AVAILABLE HERE**

Tues., Oct. 25th **STEAK NITE**

**Octoberfest**  
Sat., Nov 5th With Uncle Jeffrey

dryvillehotel.com 110 Lyons Rd. | 610.682.2466

WELCOME TO **LYONS FIRE CO. #1**  
Green Plate Specials Mon. - Thurs. 5 pm to 9 pm

Wed., Oct. 26: **Loaded Fries**  
Thurs., Oct. 27: **Burger Nite**  
Fri., Oct. 28: **Breakfast** - 7 am to 10 am  
Fri., Oct. 28 & Sat., Oct. 29: **Dinner Night** - 5 pm to 8 pm  
**Crab Imperial or Fresh Chicken Cordon Bleu**  
Fri., Oct. 28 - **Halloween Bash**  
Sun., Oct. 30 - **Wings** - 4 pm to 9 pm  
Mon., Oct. 31: **Chicken Mc Lyon**  
Tues., Nov. 1 - **Shrimp Scampi w/Pasta**

Look For Us On Facebook For Upcoming Events! SEE US @ www.lyons35fire.com

**Bowers Hotel** 298 Bowers Road, Bowers, Pa. 610.899.0183

Check Out Our New Website: [bowershotel.com](http://bowershotel.com)  
Operating Hours: Sun. thru Thurs. 11 am to 10 pm;  
Fri. and Sat. 11 am to 11 pm; Sunday Brunch Opening at 10 am

**WEEKEND SPECIALS**  
Shrimp Parmesan  
Coconut Chicken Stir-Fry

**Friday & Saturday - Prime Rib**

~ ENTERTAINMENT ~  
Open Mic: TUESDAY 7:30-10:30 p.m.  
Hiring Servers and Bartenders  
Accepting Thanksgiving Reservations

Monday: 2 Entrees & 1 Appetizer or Dessert To Share ..... 2 for \$20.00  
Tuesday: Homemade Chicken Pot Pie ..... \$7.95  
Plus Other Penna. Dutch Favorites  
Wednesday: All-You-Can-Eat Spaghetti ..... \$5.95  
Seafood Pasta ..... \$12.95  
Thursday 4-9: Certified Angus Beef  
Rib Eye or Sirloin Steak ..... \$12.95  
Fish Fry ..... \$9.95  
14 oz. Cowboy Rib Eye ..... \$13.95

★ SUNDAY BRUNCH BUFFET ★  
Now Opening at 10 am to 2 pm ..... \$12.95

Neighborhood **Ozgood's** Grill & Bar

★ DAILY SPECIALS ★  
MON. - BURGER NIGHT • TUES. - TEX MEX NIGHT - FAJITA & QUESADILLA SPECIALS  
WED. - STEAK NIGHT • THURS. - SHRIMP NIGHT  
SUN. - RIB NIGHT - 1/2 & FULL RACKS OF SMOKED BABY BACK PORK RIBS

Great Chicken, Seafood, Steaks, Burgers, Sandwiches & Wings

Friday, October 28 & Saturday, October 29  
**STUFFED WEEKEND**  
Stuffed Entrees and Appetizers with Amazing Flavor Combinations  
4 LINCOLN ROAD, KUTZTOWN, PA 19530  
484-641-5222

**OYSTER SUPPER**  
Sat., Nov, 5, 2016  
Serving 4:00 pm until 7:00 pm

**JACOB'S CHURCH**  
Serving in The Activity Center  
"HANDICAPPED ACCESSIBLE"  
8373 Kings Hwy., New Tripoli, PA  
(Near Leaser Lake)

Menu Incl: Fried Oysters,  
Oyster Stew, Oyster Pie, Fried Shrimp Platters, Fresh-Cut Fries, Bar-B-Q, Pepper Cabbage  
Dessert: Cakes & Pies...Lemon Strip, Coconut, Fruit Pies to mention a few.

Takeout Orders Prior To Event:  
610.751.5742  
Day Of Event: 610.756.6352

**PIKE TOWNSHIP SPORTSMEN'S ASSOC.**

**WEEKEND DINNER SPECIAL**  
Friday, Oct. 28, Saturday, Oct. 29, Sunday, Oct. 30  
**Chicken Marsala**

**WEEKEND BREAKFAST SPECIAL**  
Saturday, Oct. 29 & Sunday, Oct. 30 - 8 a.m. to 11 a.m.  
**Maple Cinnamon French Toast**

**WING NIGHT**  
Every Thursday from 5 p.m. to 9 p.m.

**SENIOR MENU**  
Is Served Every Sunday From Noon to 7 p.m.

**ALL-YOU-CAN-EAT SPAGHETTI**  
Served Every Sunday from Noon to 7:00 p.m.  
**\$7.95**

**BREAKFAST BUFFET**  
Is The Second Sunday Of Every Month

**MYSTIC WARRIOR**  
Friday, Oct. 28 from 8:00 to 11:00 p.m.  
Costume Judging at 9:30 p.m.

**NEXT BREAKFAST BUFFET**  
Sunday, November 13 from 8:00 to 11:00 a.m.

Like Us On Facebook for Current Menus & Up-To-Date Events At The Club.  
Contact Us: [piketwp860@yahoo.com](mailto:piketwp860@yahoo.com)

**Janelle RESTAURANT & CATERING Hall**  
Scott & Connie Gardner

360 Fleetwood Road, Bowers, PA 19511 • 610-682-0544

**LUNCH IS BACK!**

Tuesday ..... LUNCH BUFFET  
Wednesday ..... LIVER & ONIONS  
Thursday ..... CHICKEN PARM  
Friday ..... CORN PIE  
Monday (Oct. 31) ..... HOT TURKEY SANDWICH  
Tuesday (Nov. 1) ..... LUNCH BUFFET

★ HELP WANTED ★  
Hours: Mon. thru Fri. 6 am - 1:30 pm;  
Sat. 6 am - 10 am Breakfast Only; Closed Sun.

Like Us On Facebook @ Janelle Hall R/C

**HOMER'S Bar & Grill**  
21 W. Main Street, Fleetwood  
610-944-0778  
Open Mon. - Sat. from 7 am to 2 am  
Sun. from 9 am to 2 am

**SUNDAY, OCTOBER 30 - BREAKFAST**  
Mackerel, Eggs & Hash Browns 9 am to 12 pm

**MONDAY** - 5 pm to 12 am - **BURGER NIGHT**

**TUESDAY - YUENGS & WING NIGHT** 4 pm to 12 am  
\$5.25/doz. Eat-In \$6.25/doz. Takeout  
\$2.00 YUENGLING LAGER DRAFTS

**WEDNESDAY - OPEN POOL TABLE**  
7 pm to 12 am

**THURSDAY** - 5 pm to 12 am - **HOAGIE NIGHT**  
Food is available for takeout

**1ST & 3RD SUNDAYS** - 7 pm to 10 pm -  
**OPEN MIC w/MICKEY THOMPSON**

Music... **FRI., OCT. 28:** Open Jukebox 7 pm to 1 am  
**SAT., OCT. 29:** "Somebody's Circus", "Beer & Pretzels", "Admit Nothing", "Slammed Parenthood" 10 pm to 1 am

**The Quality Shoppe**  
Village Square Shopping Center  
Kutztown - 610-683-8270

★ Monday 5 a.m. to 2:30 p.m.; ★  
Tuesday - Friday 5 a.m. to 8 p.m.; ★  
Saturday 7 a.m. to 2 p.m.;  
Sunday Closed

*New Breakfast, Lunch & Dinner Menus*

TUESDAY ..... Tuna Noodle Casserole  
WEDNESDAY ..... Liver & Onions  
THURSDAY ..... Corn Pie  
FRIDAY ..... Shrimp Basket  
SATURDAY ..... Fried Egg Burger w/Fries  
MONDAY (Oct. 31) ..... Coney Burger w/Fries

THE FAMILY OF THE LATE  
*Mabel E. DeLong*

thank you for the sympathy cards, flowers and kindnesses conveyed during our recent bereavement.

A special thank you to the staff of The Lutheran Home in Topton for their compassionate care. Also thank you to Rev. Roger Ulrich and the Ladies' Aid Society of Christ (DeLong's) UCC.

Love,  
Son, Daniel; Daughter, Donna;  
and Families

**ANNOUNCEMENTS**

Advertise to 500,000 Homes with a business card size ad. You choose the area of coverage in free community papers...we do the rest. Call 800-450-7227 or visit macnetonline.com (\*191756)

Life Alert. 24/7. One press of a button sends help FAST! Medical, Fire, Burglar. Even if you can't reach a phone! FREE Brochure. CALL 1-800-746-0979 (\*191560)

**ANNOUNCEMENTS**

CELEBRATION OF LIFE SERVICE at St. John's UCC Fogelsville in remembrance of those who have passed. October 30 at 10:30am. All are welcome to come and honor those souls who have graced our lives.

Got Knee Pain? Back Pain? Shoulder Pain? Get a pain-relieving brace - little or NO cost to you. Medicare Patients Call Health Hotline Now! 1- 800-419-3684 (\*178647).

**EAST PENN VALLEY Merchandiser COMMUNITY CALENDAR**

Any nonprofit organization within our circulation area may send us notification of your upcoming events. We will publish this information in the East Penn Valley Merchandiser free of charge.

Community Calendar listings are strictly limited to 35 words or less and 1 to 2 weeks prior to the event. The Windsor Press, Inc. will not edit your copy. If your copy is longer than the maximum 35 words, your listing will not appear. We must have this information no later than the Thursday prior to publication date. Mail information to The Windsor Press, Inc. East Penn Valley Community Calendar, 6 N. Third St., P.O. Box 465, Hamburg, PA 19526-0465, or EMAIL it to: classifieds@windsorpress.com or FAX: 610.562.2770.

10/26/16, Lower Macungie Library: Ghost Stories, 7:13. Presented by local author and international expert on all things paranormal, Charlie Adams. Registration required. 610-966-6864.

10/28/16, Leesport Lock House. Come share your spooky stories around bon fire at 6:30 PM thru 8:30PM. Serving hot dogs, cider, hot chocolate and smores. Donations accepted.

10/28/16, Upper Bern Vets Meeting. Friday 7pm. At Shartlesville FC. All veterans are urged to attend.

10/29/16, Dreibelbis Historic Farm, site for Kutztown Area Scientific Paranormal Evidence Research investigation. Rt. 143 Virginville. Scientific methods demo, ghost hunting experience, hayride, bonfire, refreshments. Free parking; \$10 admission benefits Farm Society. 484-638-2720.

10/30/16, Becker's St. Peter's Lutheran Church Celebrating Love Feast and Holy Communion on Reformation Sunday, 9am service. 265 Maiden Creek Road Richmond Twp.

10/30/16, Camp Edmar Annual Scout Breakfast, 7am-11am. North of Kutztown on 737, Greenwich 3 miles, left onto Ebling Road, 1 mile to Boy Scout Road, 0.2 miles, Camp on left. Great Food, Great Service.

10/30/16, Lighthouse Baptist Church Concert by "Harmenaires". 7pm. Free Love offering taken. 2096 Independent Road, Breinigsville, Rt. 863 S near New Smithville.

11/2/16, the Virgville Grange meets 7:30pm. It is Legislative Night and they will have a "mock Presidential debate".

11/5/16, Lehigh Valley Therapy Dogs Fundraiser, "Paw-Sta" Dinner. Saturday 4-8pm. At Lehigh Lodge Rt. 100, Macungie. Donation \$8/pp.

11/5/16, Morgenland Church Annual Spaghetti Dinner 4-7pm. with Homemade Meatballs, salad, Italian/ garlic bread, beverages, homemade desserts. Walk-ins welcome. Basket raffle, Homemade Cherry Crumb Pies, Apple Dumplings, 610-395-6885 to preorder.

11/5/16, Reinholds FC Bluegrass in Banquet Hall, 138 W. Main Street (Rte 897) Reinholds. "Bluestone" along with "Chester Johnson". 2 bands, 4 sets of music. Doors open 5pm, music 6pm. Great food available. Info 610-573-0797

11/5/16, Salem Berne United Methodist Church Bazaar, 292 Salem Church Road, Tilden Township, Hamburg. 8am-1pm. Baked good, home canned food, lunch, crafts, white elephants and more.

11/5/16, Salem UCC Holiday Bazaar, Saturday 9am-2pm. 307 Covered Bridge Rd., Oley. Lunch, baked goods, canned goods, crafts, Christmas Room & flea market, 610-689-0724.

11/5/16, St Paul's UCC chicken pot pie supper from 3:30 p.m. - 7:00 p.m. 5 West Arch St. Fleetwood. Take out orders, Friday, November 4. Phone 610-944-7300.

11/5/16, St. John's UCC Old Fashioned Pork & Homemade Sauerkraut Dinner, Saturday 3-7pm. Open seating. 139 N 4th St., Emmaus. Adults \$10, under 12 \$5, Under 3 free. Tickets: 610-965-9158.

11/5/16, St. Mary's Church Holiday Bazaar, Saturday 8:30am-2:30pm. 14833 Kutztown Road, Kutztown. Homemade food, craft vendors, basket and quilt raffles. 610-683-6239.

11/5/16, St. Paul's ELC Christmas Bazaar, 2613 Old Rt. 22, Hamburg. Church basement 8am-2pm. Vendors, lunch, eat in or take out soup, cookies, bake sale, chow chow.

11/5/16, Zion's Spies E.R. Church Holiday Bazaar and Breakfast 7am-11am/noon at, 318 Spies Church Rd., Rdg Baked goods, crafts, used book table.

11/6/16, Citizen's Fire Co #2 Emmaus Basket Bingo. Sunday 2pm. Doors open 1pm. \$20/20 games, raffles, specials, non smoking, refreshments available. Only 100 tickets. Call 610-965-2097.

11/6/16, Weisenberg Church PA German Worship Service, 2:30pm. 7645 Weisenberg Church Road, New Tripoli 18066. Message: Rev. Richard Miller, Worship Leader Donald Breninger. Special Music. 610-298-2352.

**BUYING GOLD SILVER • PLATINUM DIAMONDS • COINS & WATCHES**

**ROBERT'S Jewelers**

Phone: 610-398-6970

Fogelsville Center Fogelsville, PA

Hours: Mon.-Wed. & Fri. 10-6; Thurs. 10-8; Sat. 10-4

**ANNOUNCEMENTS**

Attention Small Businesses: Simplify Your Payroll & Taxes with Paychex! New customers receive one month of payroll processing free! Receive a Free Quote! Call 800-805-0164 (\*191931)

Holding a Carnival! Fair! Festival! Jubilee! Promote it to over 1 Million readers for only \$200! Visit www.midatlanticevents.net for more details or call 800-450-7227. (\*196731).

Lung Cancer? And 60 Years Old? If So, You and Your Family May Be Entitled To A Significant Cash Award. Call 800-897-7205 To Learn More. No Risk. No Money Out of Pocket. (\*193800)

SOCIAL SECURITY DISABILITY BENEFITS. Unable to work? Denied benefits? We Can Help! WIN or Pay Nothing! Contact Bill Gordon & Associates at 1-800-208-6915 to start your application today! (\*181023)

**Check Us Out!**

[www.windsorpress.com](http://www.windsorpress.com)

**PUBLIC NOTICE**

Notice is hereby given that on or after Friday, November 4, 2016, 9:00 am at: East Penn Self Storage 14135 Kutztown Road Fleetwood, PA 19522 610-944-1141

The undersigned, East Penn Self Storage, will sell at Public Lien Sale by competitive bidding, in accordance with the Pennsylvania Self-Storage Act, in an attempt to satisfy owner's lien, the personal property heretofore stored with the undersigned by:

- 7039 - Smith
- 4555 - Grim
- 45511 - Greenleaf
- 4517 - Daigneault
- 6054 - Schlott
- 6059 - Esterly
- 4558 - Gift
- 45514 - Calm

**LOST & FOUND**

LOST CAT: \$1000 reward for the physical and safe return of my cat, Bernie. He is a black and white male, neutered, 6 years old. Lost from Schoeneck Road, Macungie PA. If found, please feed him to keep him in one place and call 610-967-3364 or 610-972-2797. If at all possible, please try to take pictures of the cat. Also, asking all residents in the area to frequently check their barns, sheds, underneath homes and decks. Please help.

**PUBLIC AUCTION**

**100s TOOLS; MILITARY MODELS; FURNITURE; ANTIQUES; HOUSEWARES**

Thursday, October 27, 2016 at 2 P.M.

Location: The Auction Center at Fogelsville, 820 Nursery St., PA 18051, just West of Allentown.

Models: 125 military vehicles, all new in box, mostly WWII & WWII German; 20 paint sets NIB. **Antiques & Collectibles:** lightning rod w/wind directional; bake oven peel; Cl "Bank" bldg. bank; minia. anvil; iron butcher fork; iron kettles & pots; flatiron; old wringer; milk can; brass blow torch; brass & copper fire extinguishers; early Underwood typewriter; 50+ inkwells & iron stands; matchbook coll.; silver plate champagne coolers; daguerreotype; dz. lg. Santas; 6-pc. chamber set; 4-pc. gilt dec. patt. glass tbl. service; Nippon relish set; asst. Dep. & Carnival glass; 100+ old btls. inc.: 4 GA Straub, Quakertown; Moyer's Dairy btl., Easton; wdn. Coke case & btls.; crocks & jugs; 30s Needlecraft mags; doz. dolls; lot German books; H Hargrove "Blacksmith" giclee; 2 K. Shaw-Peeler old Allentown prints; 100-pc. set Occ. Japan dishes; Duck table light w/Rod Arbogast signed shade. **Furn.:** nice rd. oak ped. tbl. & 4 chrs.; sq. oak china closet; oak COD; old 25-drawer wdn. tool chest; cedar chest; 6' mortised bench; slant-top desk; 4-pc. LR tbl. set; 1970s movie theater popcorn machine (working); nice Drexel mahog. 6-pc. BRS; 3-pc. maple dinette set; leather couch. **Tools:** Craftsman 10" tbl. saw, NIB; Craftsman 1-hp 15" flr. mdl. drill press; Delta 16" scroll saw; rare Craftsman pwr. mini tool kit; Craftsman dust collector; Craftsman Quiet Drive 150 psi air comp.; pony tank; wood lathe; Ridgid shop vac, OB; parts washers, NIB; Craftsman industrial router tbl. w/router; DeWalt 2-hp hvy. duty plunge router; Craftsman 1-1/2 hp router, NIB; sign crafters; trim router; Porter Cable plate joiner, NIB; B&D rotary grinder & rotary saw; Makita 10" slide compound mitre saw; Porter Cable 7-1/2" circ. saw, NIB; power planer; palm sanders; cordless drills/saws; Stanley multipurpose blower fan; Wen wet wheel; bench grinder; Quick Grip clamps; log splitter; golf hole drills; Blue Point Prof. air brush; staple guns; hole saw kits; doweling jig; adj dado blade; lots of good hand tools & hardware; Dyson DC07 Animal upright VAC; dehumidifier in OB; Harman Wood Pellet Stove; also 100+ box & row lots. Full list & photos @ www.zettauction.com.

Conducted by:  
**ZETTMAYER AUCTION CO., LLC**  
820 Nursery St., Fogelsville, PA 18051-0215  
www.zettauction.com  
PH: 610-395-8084 • FAX: 610-395-0227  
PA LIC #AY-000131-L

**COOPER WEATHER-MASTER ST2**

**Tri-Polymer Blend Tread Compound**

Specially formulated for excellent winter traction while maintaining wet and dry performance and treadwear.

**Enhanced Studded Performance**

A new stud pin hole design improves stud retention and the number has been increased allowing for the use of a greater number of studs for better traction on ice. The stud size is conveniently molded into the sidewall for easy reference.

**Computer-Optimized Random Pitch Sequence**

The tread pitch sequence has been computer-optimized to reduce tread related tire noise for increased riding comfort.

**KANTNER'S TIRE SERVICE, Inc.**

230 South Franklin St. SHOEMAKERSVILLE  
HOURS: MON. THRU FRI. 7 TO 5; SAT. 7 TO 12  
GLENN ROBERTS www.kantnerstire.com 610-562-2567

**RV'S/CAMPERS**

**KEEP YOUR CAMPER IN GREAT CONDITION! Trailer, Inspection, leak detection, roofing, carpeting, plumbing & electrical, minor repairs, AC Installation, awning, heaters & refrigeration. Maiden Creek Marine & RV, 222 south of 662 Moselem Springs. www.maidencreekrv.com. 610-944-9994.**

Fleetwood TL Camper 1999 Fixer Upper. Located in Hamburg. \$1300 obo, 484-665-3480.

GEORGIE BOY 2005 Pursuit 35ft Class A Motor Home. 4 V-10 chassis, 18,000 miles, 2 slides, non-smoking, no pets. Excellent and clean condition. 610-698-2400 after 7am

**AUTOMOBILES/ TRUCKS**

1996 BRONCO XLT Sport 5.0 AT, 126,000 miles, runs great, well maintained with receipts, inspected through 2017, too much more to list, Call 484-951-0175.

2002 Chevrolet Suburban: LT, 4wd, automatic, PS, PB, PL, PW, tilt, cruise, heated leather seats, new tires, new inspection, great condition, 124K, \$5500. 484-388-1986.

2005 Enclosed Car Trailer, dual axle, electric brakes. Receiver and new tie downs included \$1800; Penna license plates, 4 Porcelain, 4 painted, 1912, 1919, \$400 570-754-7976.

**Kelchner Cleaners**

Dry Cleaning & Coin Laundry

...for dry cleaning elegance since 1945

**Kutztown**  
234 N. Whiteoak Street  
610.683.7903

**Fleetwood**  
13 N. Franklin Street  
610.944.8241

www.kelchnercleaners.com  
Email: pam@kelchnercleaners.com

**COMPUTERS/OFFICE**

**A+ COMPUTER REPAIR: Slow Computer, Popups, Virus Infections? I will come to your home or office and fix all hardware and software problems on Lap tops, Desktops, and Servers. Very good rates. Local References. Call Mike at 610-285-8321 or email support@easytcs.com**

FOR SALE: RISO COPIER Model RZ220. Xerox Color Copier Model Color Cube 8570DN-33. Being sold by St. John's Lutheran Church, Hamburg, PA. Call 610-562-8732 to see items.

**Nancy's Computer Service: Need help with your computer or laptop? Updates, Virus infections, software install/Clean up your computer if running slow/ etc. Printer setup. Very reasonable rates. Your home or mine. Call for prices. 610-683-6680**

**2008 Buick LaCrosse CXL. Only 37,000 miles. All leather interior, heated seats, drives like new. Asking \$6,750. Call Joe 484-553-4963.**

60 ton ACCO Hydraulic Press 3 stage. New gaskets seals o-rings 2014 VGC \$1100; Victorian Hall stand beveled mirror storage in seat \$400; 20"x30" Porcelain sign double sided Greyhound lines \$400; 570-754-7976.

95 toyota corolla can be fixed. Just inspected 220k miles \$500 or best offer call between 8am-noon 610-683-5784 or 95 Honda civic needs motor everything else is there, best offer 484-772-9327. If no answer leave message.

**CARS/ TRUCKS WANTED!** All Makes/Models 2002-2016! Any Condition. Running or Not. Competitive Offer! Free Towing! We're Nationwide! Call Now: 1-888-368-1016 (\*190650)

**CARL & SMITH COAL HAULING**

HEGINS, PA 17938

STOVE, NUT, PEA, BUCKWHEAT, RICE

\$240/Ton

GOOD QUALITY ANTHRACITE

CALL: 610.562.4875 AFTER 5 PM

**"Use An Old American Fuel!"**

# FALL OPEN HOUSE

**8% Discount On All In-Store Purchases!**  
(Excluding Feed, Bedding & Repairs)

**Food & Door Prizes**

**Fresh Homemade Baked Goods**

**Friday & Saturday, October 28 & 29**  
Fri. 8-7; Sat. 8-5

**Saturday Only**

- BBQ Pork Sandwiches
- Horse Training Demos (Forenoon Only)
- Free Horse & Wagon Rides

**LEID Shoes & Saddlery**

**Farnam**

**BLUE SEAL**

**FEEDS & NEEDS - 700 Kohler Rd., Kutztown, PA 19530 • 610.682.2760**  
Hours: Monday - Friday 8 a.m.-7 p.m.; Saturday 8 a.m.-5 p.m.

**WANTED TO RENT/BUY JEWELRY WANTED:** All kinds. Old costume, new costume, used, designer. Bracelets, rings, pins, earrings, necklaces, watches. Good prices paid. Call 610-781-4951.

**TOYS WANTED:** Trains and accessories, all makes. Toy soldiers and other figures, Christmas things, space toys, robots, mechanical banks, trucks, cars, boats, wagons, buildings, fire engines, airplanes, windups, pedal cars, marbles, farm toys, candy, containers, erector sets. Call George 610-372-1681 with any old toys.

**MISCELLANEOUS**

**FOR SALE:** Machine Company closing. All equipment must go. Miscellaneous tools, measuring instruments, lathes, mills, drill presses, welder saws, cutting tools. 610-926-4766

## Trexler Auto Sales

1033 Trexlertown Rd., Trexlertown, PA  
610-417-0282

**Most Cars Include 6 Month Warranty**

2012 Ford Focus SEL 38K	\$10,990
2011 Ford Fiesta SES Loaded, One Owner, Only 51,000 Miles	\$8,990
2010 Toyota Corolla	\$8,990
2010 Kia Forte One Owner	\$6,990
2009 Nissan Sentra One Owner	\$7,990
2009 Suzuki SX4 Touring AWD	\$4,990
2008 Hyundai Elantra Like New	\$5,990
2008 Chevy Cobalt One Owner	\$5,990
2007 Toyota Solara XLE Convertible One Owner, 69K	\$10,990
2007 Infiniti G35x AWD	\$10,990
2007 Honda Accord EX-L One Owner, Loaded, Only 72,000 Miles	\$9,990
2007 Scion TC Only 79,000 Miles	\$8,990
2007 Mazda Mazda3 Like New, One Owner	\$7,990
2007 Ford Focus ZX4	\$3,990
2007 Ford Focus ZX3	\$1,990
2006 VW Passat	\$5,990
2006 PT Cruiser	\$4,990
2006 PT Cruiser	\$2,490
2004 Toyota Matrix	\$6,990
2003 Ford Taurus	\$2,990
2002 Nissan Altima	\$4,490
2002 Toyota Corolla Low Miles	\$3,990
2001 Hyundai Elantra 64K	\$3,990
1995 Ford Taurus Low Miles	\$1,390

**Jamar Groceries**  
More 4 Less

61 Kempville Rd., Kutztown, PA 19530  
HOURS: Mon.-Thurs. 8 a.m. - 5 p.m.; Fri. 8 a.m. - 6 p.m.; Sat. 8 a.m. - 4 p.m.  
610-683-6055

**Discount Groceries And Product Overruns**  
• Fresh Produce • Bulk Foods • Milk • Lunch Meats & Cheese • Frozen Foods

**SPECIALS EFFECTIVE OCTOBER 26 TO NOVEMBER 1, 2016**

Pierre's Sundae Ice Cream	1.5 qt.	\$1.89
Hope's Royale Cookie Dough	lb.	\$1.29
Southern-Style Diced Hash Browns	32 oz.	\$1.09
Fruit on the Bottom Yogurts	12 ct. case	\$2.75
Oscar Mayer Smokies	14 oz.	\$ .99
Bachman Jax Cheese Puffs	6 oz.	\$ .99
Nabisco Oreo S'mores Cookies	10.7 oz.	\$1.39
Malt-O-Meal Marshmallow Mateys	32 oz.	\$2.29
Deli: Laubscher Monterey Jack Cheese (Chunks)	lb.	\$2.69
Hormel Cooked Ham	lb.	\$2.29
Produce: Canadian Red Potatoes	5 lb.	\$1.99

WE WILL BE HAVING A WEEKLY DRAWING FOR A \$25.00 GIFT CERTIFICATE FROM NOW UNTIL APRIL. YOU WILL RECEIVE AN ENTRY SLIP W/PURCHASE.

## STILL RENTING? WHY?

**Get on the road to Home Ownership!**

New Homes - Preowned Homes & Rent or Own.

Explore options for your budget.

**< 800-903-5711 >**

HerefordHomes.com

**AUTOMOBILES/ TRUCKS**

Turn that junk into cash! Buying cars, trucks, heavy equip., farm equip. & classics. Available for farm clean outs. DA Auto Salvage. 610-756-3848 or 610-451-6280.

**WANTED: Junk Cars And Trucks.** Cars \$150, Trucks \$200; 610-392-2805.

**WE WILL DISPOSE OF Your Used Motor Oil and Transmission Oil at No Charge.** Monday through Friday, 7am to 4:30pm, Saturday 8am to 11:30am. STEVE MOYER SUBARU, 201 S. Centre Ave., Leesport, PA, 19533, 610-916-7000.

**WANTED TO RENT/BUY CASH FOR YOUR CAR,** Call 610-916-7000. Steve Moyer's Subaru.

**Fill Your Freezer with Quality Grass fed Black Angus Beef, approx. 1200 lbs. Each. \$1.25 per pound, live weight. Processing available. Call for details. Also grain fed Angus Beef Available Berks Co. Call 610-683-5204.**

AHL Phantom Ice Hockey Tickets Available. Season ticket holder has 2-4 premium seats available for most home games. Ph. (610) 944-5353

**JACK MILLER ANTIQUE CLOCK REPAIR:** Also new wind up wall, mantel, tall clocks and battery clocks. 50 years servicing clocks. Macungie, PA 610-395-1543.

2 Heavy Duty Table Saws; DeWalt Jet with a dozen blades. 2 gas power air compressors and several used weed eaters \$500 for all above obo, 610-966-3200.

**AUTOMOBILES/ TRUCKS**

I Pay For Cars: I'll buy your used car, truck or classic. Licensed dealer pays cash. Don't sign a blank title, FREE PennDOT notary service + pickup. www.ipay4cars.com Max-atawny Auto Sales, 15320 Kutztown Rd. Kutztown 610-683-0480.

1966 FORD FAIRLANE convertible, good condition, \$20,000 obo. Call and leave message. 610-562-4751.

1991 CHEVY CORVETTE Turquoise, 78,000 miles, \$10,000 or best offer, call 610-509-4369.

**AUTOMOBILES/ TRUCKS**

Immediate Cash Paid For Your Vehicle running or not, 484-221-2278.

**J&J TOWING:** Always Buying Junk Cars, Wrecks and Your Unwanted Vehicles. Paying from \$100 & up. Call Jorge at 484-955-8386.

**WE BUY OLD, Classic, Vintage, and Exotic Cars. \$\$\$ We pay cash \$\$\$.** Will pick up vehicle and handle title! Call Ruozzi Brothers Collection at 610-398-9700 or contact@rbcollection.com

**Allure50 Pellet Stove** | Performance | Engineering Excellence

• Heats 1,000-2,800 sq. ft. with 13,300-52,600 BTUs, based on climate and home efficiency  
• 92-lb. hopper capacity  
• EASY Touch Control with scheduling, cleaning prompts and fuel gauges  
• Glass-front option and multiple color choices give a sleek, polished look

**Kegeerreis Stoves**

7758 Rt. 183, Bernville, PA 19506  
www.kegeerreisstoves.com  
610-488-0890  
Mon.-Fri. 9-6 • Thurs. 9-8 Sat. 9-1

**Ernie Martin EXCAVATING**

Residential - Agricultural - Insured -

72 Dryville Road  
Fleetwood, PA 19522  
PH: 610-682-2050

- ◆ Excavations
- ◆ Basement Building Pads
- ◆ Grading
- ◆ Trenching
- ◆ Septic Systems
- ◆ Hauling

# DAVID W. TIDD

## ATTORNEY AT LAW

- DUI/Criminal
- Bankruptcy
- Divorce

FREE CONSULTATIONS  
Serving Berks, Lehigh, & Surrounding Counties  
In-Home Consultations Available  
Payment Plans

**Fleetwood, PA | 610.838.8700**

55 Gallon open top steel drums \$11 each. 275 Gallon plastic totes with metal cages \$25 each. Produce bins, cardboard, good for watermelons, etc. \$3 each. Plastic crates 12x20x11" high stackable \$3 each. 48X40 4-way wooden skids \$2.50 each. Call 215-997-9043.

Gas heater 50K BTU upflow forced air new in box \$500.00. 4 ton and 5 ton R22 condensers new in box \$500. Gas fireplace log sets 18" and 24" new in box. GMC 7000 26' box truck with lift gate, gas 5 speed transmission \$6000. Call 215-997-9043.

FOR SALE: Antique Window pane Glass. Approx. 75 pieces. Still in double hung frames \$45; 484-332-2653.

**TO PLACE YOUR CLASSIFIED AD:**  
Call: 610.562.6595 or email: classifieds@windsorpress.com

**TRUCKS/VANS/SUVS:**

2012 Nissan Rogue	\$8,990
2009 Honda Pilot EX-L Like New	\$14,990
2007 Toyota Sienna XLE Loaded	\$10,990
2007 Jeep Compass	\$5,990
2006 Chevy TrailBlazer 4WD 7 Passenger	\$7,990
2006 Chevy Equinox AWD	\$6,990
2005 Toyota Sienna LE One Owner	\$6,990
2005 Ford Explorer Limited 3rd Row, 4x4	\$6,990
2005 Kia Sorento AWD	\$6,990
2002 Ford Explorer XLT 4WD	\$4,990
2004 Ford E250 Cargo Van	\$4,490

## BUY-HERE-PAY-HERE

On Select Vehicles

Full-Service Garage Offering Work On All Makes & Models  
We Do State Inspections.

**We Pay Cash For Your Used Car, Truck or SUV!**  
Hours: Mon., Tues. & Thurs. 9:00-7:00;  
Wed. & Fri. 9:00 to 5:00; Sat. 9:00 to 3:00; Closed Sun.

**www.trexlerautos.com**

**MISCELLANEOUS**

4 Goodyear P215/60R16 Tires, good condition, \$140; small wood stove, good for workshop or garage, excellent condition \$75; 16" Echo Chain Saw, 452 VL, extra chains, good condition, \$100; Call 610-926-1694. after 4pm.

**MISCELLANEOUS**

Must Remove, Commercial Steel Desk with Mahogany top, six drawers, one section 6'L, one 4 1/2'L exc. Cond.; Verizon Navigator Flip Phone, with charger \$35, excellent condition, 484-358-6100, Iv. Message.

## PUBLIC AUCTION

**FURNITURE, COLLECTIBLES, TOOLS, QUILTS**  
Friday, October 28, 2016 at 3:00 PM.

**Location:** Auction held in Beltzner Hall at the Kutztown Fairgrounds, 144 N. Whiteoak St., Kutztown, PA 19530.

**Items:** Spinning whl.; flax whl.; grained blanket chest; cedar chest; Windsor-style rockers; press back rockers; 6 press back chairs; sm. wicker rocker; sm. painted rocker; Vic. parlor chairs & others; Depr. BRS; Dep. DRS; J.P. Seeburg Piano Co. oak frame; Nickelodeon w/stained glass door and approx. 30 rolls; sm. settee; EdenPURE heater; Ethan Allen dresser w/mirror; Ethan Allen book-cases; round oak tbl.; butler's desk; open top dry sink; sm. washstand; sm. roll top desk; paw foot drop-leaf tbl. w/chairs; drop-leaf wall tbl.; clothes tree; curio cab.; coffee tbl.; kneehole desk; sm. roll-top desk; jewelry armoire; sm. cigar stand; Planet Bingo-Ball penny mach.; 1948 Globetrotters poster (Kutztown); Lionel 266 O-gauge train w/box; asst. train pcs.; C.I. Hubley monkey; C.I. terrier dog; 1938 reprints action comic books; quilts; sewing items; bedding; hankies; buttons & sewing items; linens; Lladro figs.; David Winter cottages; asst. glass-ware; crocks & jugs; sm. hand crank Victrola; copper wash boiler; sm. bleeder; washboard; local adv. Kutztown Bottling Works (btl., crates & thermo.); Coke cooler; Yuengling sign & other beer adv. pcs.; Louie Deturk plate; Kutztown ruby flash & other local adv. pcs.; ceramic Christmas tree; jewelry; linens; asst. kitchen items; yellowware mixing bowls; butter print; copper luster; chamber set; stomper; coffee grinder; fountain pens; Longaberger umbrella stand; hats; tins; Minnie Mouse cookie jar; sheet music; few asst. tools; wheelbarrow; stepladders; ext. ladder; asst. tools; handled tools; plus many other items.

**Terms:** Cash or PA check only. Auct. Note: Lg. quality auction. Note location and day. Watch for photos on www.auctionzip.com the week of the auction.

**Auct: DAVID P. LOEB, AU-002753-L Auction For: Lenhartsville, PA 19534 LUCILLE & BARNEY 610.756.4260 BIEBER ESTATE**

# Card of Thanks Form

PLEASE CLEARLY WRITE THE INFORMATION YOU WOULD LIKE IN THE AD ON THE LINES BELOW.

\_\_\_\_\_  
 \_\_\_\_\_  
 \_\_\_\_\_  
 \_\_\_\_\_  
 \_\_\_\_\_  
 \_\_\_\_\_

**CHOOSE A PUBLICATION:**

- East Penn Valley  Northern Berks  
 Both

Issue Date: \_\_\_\_\_

Phone #: \_\_\_\_\_

Name: \_\_\_\_\_

Address: \_\_\_\_\_

**Submit information & payment to:**



6 North Third Street  
 PO Box 465  
 Hamburg, PA 19526-0465  
 610.562.2267  
 1.800.562.5521  
 FAX: 610.562.2770

OR submit the online form located on our website: [www.windsorpress.com](http://www.windsorpress.com)

OR E-mail: [display@windsorpress.com](mailto:display@windsorpress.com)



## Card of Thanks

The "Card of Thanks" can only be used for illness or bereavement.

Actual Size of Ad  
 Cost: **\$17.50**  
 per week/per paper

## Fall Build Specials!

24x30x10 ... \$7,300	30x64x10 ... \$13,850
24x40x10 ... \$8,500	30x48x12 ... \$12,600
30x30x10 ... \$8,300	40x60x14 ... \$19,100
36x48x10 ... \$13,400	40x80x14 ... \$23,600

**LIMITED TIME OFFER - CALL FOR DETAILS!!**  
**Fall Prices Good Thru November 15, 2016**  
 Prices Include Materials, Delivery, Tax and Labor Within 75 Miles of Schuylkill Haven, PA 17972  
 Many Other Stock and Custom Sizes To Choose From

### POST FRAME PRECISION POLE BUILDINGS

**FREE Estimates** | **1-877-POLEBARN** | **1-877-765-3227**  
[www.postframeprecision.com](http://www.postframeprecision.com) | [www.pfppolebuildings.com](http://www.pfppolebuildings.com)

Serving PA, NJ & MD

**MISCELLANEOUS**

**FOR SALE;** Red Aromatic Cedar Boards. Rough sawn, 5/4 thick, wide boards, 9ft. Long 300 bd. ft. \$900; 484-332-2653.

**GENERAC Generator,** produces GP7500, 1.9 hours, like new, best offer. 610-966-2596.

**Immediate Cash Paid For Your Vehicle running or not, 484-221-2278.**

**1/2 PRICE SALE:** Shelves for Truck, 3 sections 52"x14"wx44"h \$100 each; Roof rack for E250 Ford; Electric breakers over 100; Service panel 100 amps; Wiel McKlien boiler 100K gas; Corrugated fiberglass panels white 4'x7'; Storm door 36x82 \$100 each; Step ladder 12' comm. Grade fiberglass; Garage door, fiberglass, tension bar & tracks, no window, white 96"x96" \$250; 610-706-0588.

**SEASONED FIRE WOOD: 100% Split Oak \$200 or split mixed hardwood \$180 per face cord. All cut 20" length. FREE Delivery 15 mile radius Fogelsville Area. Limited Supply! 484-357-6171.**

**MISCELLANEOUS**

**CIDER PRESS** car boyds scapple, kettle, oak barrel. 610-334-4569

**FIREWOOD FOR SALE: \$100 a cord. Call 610-562-8641.**

**FOR SALE;** Lionel Trains. "O" Gauge. Post War and Modern Era. 484-332-2653.

**MISCELLANEOUS**

**"JUKEBOXES" For Sale:** Wurlitzer, Seeburg, Rowe AMI, Rock-ola. Call 610-944-9403 for appointment. Juke Box Service Available. Family Room Fun!

**Old Guitars Wanted. I will buy old guitars and guitar parts/ projects by Fender, Gibson, National, Martin, Guild etc. for cash! Dave 800-216-8936, 610-428-1103.**

**Truck Load of Closeout Caulking** Tytan, 10oz tubes: 8 colors, mostly clear Neutral Cure Silicone Full skid \$99/Tube, 2 Skids \$89/Tube, 3 skids \$79 tube Shipping Available 717-445-5222 (\*198760)

**MISCELLANEOUS**

**Acorn Stairlifts.** The AFFORDABLE solution to your stairs! Limited time -\$250 Off Your Stairlift Purchase! Buy Direct & SAVE. Please call 1-800-410-7127 for FREE DVD and brochure. (\*174061).

**Safe Step Walk-In Tub Alert for Seniors.** Bathroom falls can be fatal. Approved by Arthritis Foundation. Therapeutic Jets. Less Than 4 Inch Step-In. Wide Door. Anti-Slip Floors. American Made. Installation Included. Call 1-800-906-3115 for \$750 Off (\*184511)

**FOR SALE:** National Geographic Magazines, 1989 to and including 2016. 610-944-8889.

**MAYTAG**  
**Model MFI2269FRZ - 22 cu. ft. Refrigerator**

- Fingerprint Resistant Stainless Steel
- Beverage Chiller™ Compartment
- Temperature-Controlled Wide-N-Fresh™ Deli Drawer
- BrightSeries™ LED Lighting
- 10-Year Limited Parts Warranty on the Compressor
- Factory-Installed Ice Maker

**DAVID'S ELECTRIC, INC.**  
 314 Main St., Emmaus • 610-965-4282  
 "In Business Since 1946"

**MISCELLANEOUS**

**CREDIT CARD DEBT** Crushing You? Call DEBT ACTION GROUP. For Limited Time, Retain Our Services for FREE. Slash or Eliminate Your Balances! Call for details: 1-800-611-2316 (\*195264)

**MISCELLANEOUS**

**FOR SALE;** Vintage Violin with New bow and Case \$45; Also 3/4 size Violin with case and music stand \$25. 484-332-2653.

Join Us Now On FACEBOOK!  
 The Windsor Press, Inc

## PUBLIC AUCTION

**2007 CHEVY COBALT LT, J.D. GATOR CX, TROY-BILT GTX LAWN TRCTR., 50+ TOY FARM TRCTRS., APPROX. 50 BEER TRAYS, QUILTS, ASST. TOOLS, FURN., ANTIQUES & COLLECTIBLES**  
**Friday, October 28, 2016 at 1:30 PM**

**Location:** Saucony Hall, 85 Industrial Ave., Kutztown, PA 19530. From E. Main St. in Kutztown, turn onto Willow St., 1 blk., right onto Industrial Ave. to hall on right.  
**Furn. (1:30):** 5-pc. Heywood Wakefield BDRS; 5-pc. maple BDRS; mdrn. oak BDRS; Empire ch. drwrs.; early 1/2 spindle settee; rope beds; mdrn. dry sink; cherry canopy snlg. bed; 4 graduated stackable stands; cedar chest; asst. tall-case clocks by Eli Hoch; décor. & oak rckrs.; 4 PA House cherry dining chrs.; drum tbl.; screened dr. pie safe; 5-pc. porc.-top brkfst. set; porch benches; dbl.-lidded wd. box; curio cabinets; drop-leaf tbls.; recliners; sofa; lrg. aquarium w/accessories. **Toys (4:45):** 50+ farm toys inc.: 1/8 scale Ford 4000 & Farmall M white Demonstrator; Special Edition I.H. 966, 1066, 1466, 1566 & Hydro 100; Farmall Super M w/mntd. picker; Massey Harris 102 Louisville Puller; Ford 901 Dealer Demo; Oliver 77 w/#82 sickle mwr.; J.D. 4010 White 2-35 & 6105; Case 800; A.C. D-21; MF 850 combine; MF 50E industrial; Cockshutt; IH TD-340 crwlr. & more. **Antqs. & Collectibles:** Dbl. brass hanging lamp from Keystone House Hotel in Kutztown; Sessions & Ingraham mantle clocks; oak Gingerbread clock; New Haven beehive clock; pr. Roseville vases; 1985 L.B. pottery candlestick; Dorothy Long & White pottery; Fiestaaware; pink luster handleless cup & saucer; Candlewick & Fostoria glass; Carnival glass Roundup bowl & Butterfly Bonbon; Pyrex nestling bowl set; Danners Dairy S/P shakers, flyswatter, key chain & pntd. 1/2 pint milk bottle; Fleetwood Dairy pntd. quart & Hop-A-Long Cassidy milk bottles; Frank Titlow Tipton bottle; wdn. Reading Bone Fert. therm.; porcln. Prestone therm.; KKK membership locket; 50+ beer trays inc.: Betz, Old Reading, Old Dutch, Sunshine, Ortlieb's, Olympia, Iroquios & others; E.. Frederick Kutztown brass ladle; Acme egg scale; brass left facing terrier dog doorstop; Cl dog doorstops; Cl rabbit choc. mold; Cl banks; Cl porch bells; dengel schtock; brass pie crimpers; splitwood & rye baskets; Aladdin kero. lamp; Mercedes & Underwood typewriters; gray agataware; crocks & jugs; beaded purses; early quilts; doilies; old hats; new K-Bar knives; full boxes old 22 ammo. **Tools:** Stanley planes; broad axes; oak machinist's tool chest; Craftsman wrench & socket sets; lg. bench vise; plus lots asst. hand tools. **Cars & Trctrs. (6:30):** 2007 Chevy Cobalt LT 4-dr. auto., PW & locks, inspected, 30,000 mi.; J.D. Gator CX 2 whl. dr., 304 hrs.; Troy-Bilt GTX 16 hydro. trctr. w/mwr. deck & snow plow, 1374 hrs.; Bolens 1050 trctr., 3 spd. w/high & low & snowblower; echo string trimmer; Poulan elec. pole chain-saw; plus more not mentioned. **Terms:** Visa/MC/Disc. 3% admin. fee waived for cash or Pa. check. 6% PA sales tax.

**Auct: CLARENCE N. SHIRK AUCTION SERVICE**  
 AU-3757-L • 610-683-5093  
 RANDALL S. SHIRK AA019415  
[www.auctionzip.com](http://www.auctionzip.com) ID#4430

**Auction For: ELI HOCH ESTATE, MR. & MRS. ERNIE SOLOMON & OTHERS**

## Metal Trim Bending Up To 21'

Standard and Specialty Trim

### Trimline Manufacturing, LLC

72 Willow St., Kutztown, PA 484-388-3893  
 Daniel Loewen, Owner  
[trimlinemanufacturing@gmail.com](mailto:trimlinemanufacturing@gmail.com)

## PUBLIC REAL ESTATE AUCTION

**95 ACRES LYNN TWP. FARM IN 3 PARCELS**  
**Saturday, November 5, 2016 at 11:00 AM**  
**Location:** 5212 Schochary Rd., New Tripoli, Lynn Twp., Lehigh Co., PA 18066. From Kistler Valley/Holbens Valley Rd. in Lynnville, turn south onto Schochary Rd. to property on right.  
**Parcel #1:** Consists of 61.61 acres of farmland & some woodland, with a 1644 sq. ft., 2-1/2 story brick farmhouse and a 1-1/2 story, detached 2-car garage. Full length front porch on house. First flr. has kit. w/oak cabinets, family rm., LR & laundry rm. A semi-open stairway to 2nd flr. which has 4 bedrms. w/closets & full bath. Attic storage, full basement w/cement flr., 100-amp circuit brkr., elec. service, oil-fired hot water heat. On-site well & septic, approx. Annual Taxes: \$2,691.  
**Parcel #2:** Located directly across the road from parcel #1 consists of 22.6 acres of farmland & some pastureland. Approx. Annual Taxes: \$356. **Parcel #3:** is located along Schochary Rd. north of Holbens Valley Rd. on right consists of 9.7 acres of farmland. Approx. Annual Taxes: \$156. All three parcels are in Clean & Green. The development rights have NOT been sold off. There is approx. 80 acres tillable among the three parcels. **Call for appoint. to look at farm: 610-298-2400.**  
**Terms:** 10% down payment day of auction in cash or honorable PA check, balance on or before 60 days.  
**Auct: CLARENCE N. SHIRK AUCTION SERVICE**  
 AU-3757-L • 610-683-5093  
 RANDALL S. SHIRK AA019415  
[www.auctionzip.com](http://www.auctionzip.com) ID#4430

**Auction For: WILLIAM L. KISTLER JR. & PHILIP C. SPROGER**  
 Steckel & Stopp, Atty.  
 125 S. Walnut St., Suite 210  
 Slatington, PA 610-760-1644

**NORTHERN BERKS Merchandiser AND EAST PENN VALLEY Merchandiser**  
 Serving More Than 71,500 Homes & Businesses PLUS Worldwide With Our Online Editions!  
 PUBLISHED EVERY WEDNESDAY BY SINCE 1958

SIX NORTH THIRD STREET  
 P.O. BOX 465  
 HAMBURG, PENNSYLVANIA 19526-0465  
 610.562.2267 1.800.562.5521  
 CLASSIFIED: 610.562.6595 1.800.220.3053  
 FAX: 610.562.2770  
[www.windsorpress.com](http://www.windsorpress.com)

OFFICE HOURS: MONDAY - FRIDAY 8:00 A.M. TO 5:00 P.M.  
**YOU CAN CALL, FAX OR EMAIL US ANYTIME**  
 Family owned and independent since 1958  
**WE ARE HERE TO SERVE YOU!**

**SALES/MARKETING:** Jim Brandt, Greg Muntz  
**RECEPTIONIST:** Bonnie DeLong  
**CLASSIFIED ADVERTISING:** Bonnie DeLong  
**DISPLAY ADVERTISING/GRAPHICS DEPT.:** Marilyn Brandt, Dolores Deisher, Linda Hartman, Lori D. Kleinsmith (asst. mgr.), Carol Marko, Bonnie A. Schaeffer (mgr.)  
**PRODUCTION:** Mae Berger (Retired), Chad Gromlich, Lee Hess, Greg Miller, Allen Rauch, Ruth Rosado, Barbara Stewart  
**DISTRIBUTION:** David Wisniewski (mgr.)  
**COMMERCIAL PRINTING:** Ryan Strause  
**CONTROLLER:** Matt Figard  
**PRESIDENT:** George Mitten

The Windsor Press, Incorporated, publishers of the Northern Berks Merchandiser and East Penn Valley Merchandiser, reserves the right to review all material submitted for publication, and to reject any material, in whole or part, which The Windsor Press, Incorporated, in its sole opinion, deems inappropriate for publication. We assume no financial responsibility for any typographical errors in any advertisement, but will reprint that portion of an ad in which an error occurs.

The closing time for both the Northern Berks Merchandiser and the East Penn Valley Merchandiser "classified advertisement" and the East Penn Valley "display advertisement" is Thursday at 5:00 p.m. of the week prior to publication; the Northern Berks display advertisement is Friday noon. Any deviation from this will be published in both papers.

MEMBER OF Greater Hamburg Business Association Greater Schuylkill Haven Area Business Association

MACPA CIRCULATION AUDIT BY CIRCULATION VERIFICATION COUNCIL

Find Us On Facebook!

# Hamburg Antiques Center

20 S. 4th St., Hamburg, PA  
Family Owned and Operated  
Located in the heart of Historic Hamburg, Pennsylvania



**Exciting Items Stocked Daily**

Furniture	Primitives
Books	Pottery/Glass
Jewelry	Arts/Prints
Advertising	Ephemera
Vintage Toys	Linens
Kitchen	Lighting

Collectibles and So Much More  
**Buying and Selling**

**484.665.3636**  
**hamburgantiquesctr@aol.com**  
Business Hours: Mon., Wed., Thurs., Fri. & Sat. 10:00 a.m. to 5:00 p.m.  
Sun. 11:00 a.m. to 4:00 p.m.; Closed Tuesdays

## BICYCLES



Starting at **\$299**



**610-641-0183**

**Jason's Bikes**  
141 Old Tipton Rd., Mertztown  
Next To Brandywine High School

### Topton's Hometown Real Estate Office

## AMF Real Estate Services

"From our Home to Yours"  
Call Direct: **610-914-9509**  
E-mail: [alanefalcone@gmail.com](mailto:alanefalcone@gmail.com)  
**www.amfres.com**  
**CALL: 610-641-0444**

Office Location at:  
108 W. Franklin St., Tipton, PA 19562  
**Professional Real Estate Services**



Alane Falcone, Realtor

**SERVING ALL OF BERKS and Beyond**



**43 W. Franklin St., Tipton Single**  
Beautiful 2-Story Brick Colonial, 3 bedrooms, 2 full baths, finished attic bonus room. Fully renovated with all newer systems, roof, windows, maintaining its original character and charm with natural woodwork and wood flooring throughout. You won't want to miss seeing this warm and inviting home. 1-car detached garage. Fenced yard. MLS #6872659 ..... \$208,000



**106 S. Richmond St., Fleetwood**  
Here is your opportunity to own an affordable home in Fleetwood Schools: 3 BR, 1-1/2 bath with 1st floor laundry. Spacious room sizes. Maintenance free exterior. Bring your creative ideas to make it shine. Minutes from Deka. MLS #6807859 ..... \$84,900

THINKING OF BUYING. We can provide you with a custom home search.  
THINKING OF SELLING. Call us for a free market value analysis of your home, land or farm.

## GIVLER'S AUTO CLINIC & Trailer Sales

www.givlertrailers.com

- State Inspection • Emissions
- 4-Wheel Alignment
- All Major & Minor Repairs

### Haulmark TRAILER SALES

The Best Name Behind You For The Long Haul

## SURE-TRAC

- Utility Trailers • Car Haulers

The One You Want Not In Stock? We Can Order It.

Hitch Installation Available - See Us For Your Best Deal!  
162 N. Centre Ave., Brad Givler, Proprietor  
P.O. Box 365 Shop: 610-926-8826  
Leesport, PA 19533 Cell: 484-955-3487  
Mon., Tues., Thurs. & Fri. 8:30 - 5:30; Wed. 8:30 - 8:00;  
Saturday - Please Call

### HOME IMPROVEMENTS

**TERRY L. SCHAEFFER:** Remodeling Contractor. Siding, Soffit, Concrete, Roofing, Decks, Rain Gutter Work, Replacement Windows, Doors, Paneling, Finished Basements and More. Fully Insured, Free Estimates. 610-926-3574. PAOAGHC 15177.

**PINE TONGUE AND GROOVE BOARDS:** 1x5 Beaded on one side, edge vee on opposite side. Great for walls, ceilings or wainscoting, \$.48/Lin. ft. Mountain Wood Co. 610-756-6381 or go to [mountainwood.com](http://mountainwood.com)

### HOME IMPROVEMENTS

**I'll Paint Anything, anywhere, anytime. 3 Keys to a good job, Preparation, Preparation, Preparation. Satisfaction Always Guaranteed. Call David, 610-468-8498.**

**Master Electrician. No job too small. Licensed #PA093516 & Insured. Free Price Quotes. Reasonable prices. Todd Haring 484-951-8624.**

### HOME AND PROPERTY MAINTENANCE:

Interior, Exterior Painting, Wallpapering, Pressure Washing, Remodeling, Woodworking, Cabinetry and more. Call **RUTHERFORD'S HOME IMPROVEMENTS** at 610-756-4375.

### THOMAS AC & HEAT.

Your Independent Oil Repair Co. Gas, LP and Heat Pumps Too. Cleanings, Water heaters, October Special \$60 Service Call. Air Conditioning Our Specialty. 610-780-4712.

### TWO OLD MEN WITH TOOLS. One Call Does It All.

Renovations, Decks, Additions, Plus Much More. 25 yrs. Experience. Free Estimates. Licensed & Insured. PA#094465. 610-401-3373, 717-471-5090.

### BARRY HAUSMAN PAINTING:

Interior, Exterior. Specializing in Farmhouses, Barns, Log Houses, Ranch, Townhouses, Apartments, Barns etc. Serving Lehigh Berks and Northampton Counties. Call for Openings and Appointments. Fully insured. Custom Painting. Breinigsville, PA 610-395-5662. PA#066681. Now Booking for Winter Interior Painting at Reduced Rates.

### Keep Your Boat in Great Condition!

Trailer Inspection, Engine, Gear Case Work. Repairs & Installations. Custom made boat covers and canvas repairs of sale. Maiden Creek Marine & RV, 222 south of 662 Moselem Springs. [www.maidencreekrv.com](http://www.maidencreekrv.com). 610-944-9994.

1988 Sea Nymph, 14', 20 hp. Mercury motor, Cox trailer, cover, trolling motor, fish finder. All for \$1500, Call 484-788-2935.

### HOME IMPROVEMENTS

**JOHNSON'S REMODELING** All types of home improvements, dump truck & backhoe services, Windows, Doors, Etc., Basements & Water Proofing, Drainage Pipe. Call Bill Johnson 610-509-4052. Snow Removal and Plowing.

### BOATS/MOTORS

ALL ELECTRICAL BY GIOVANNI Master Electrician, fully insured, for all your electrical needs. Local electrician. 610-780-7713 or 484-575-7057.

### MOYER'S CONSTRUCTION

28 yrs. Experience All Phases of Construction. Additions large & small. See us for all you remodeling needs, Kitchens, Baths, Decks, Etc. Free consults and estimates. Call 484-955-4032. PA011232

### e-Subscribe to the Northern Berks & East Penn Valley Merchandiser at

[www.windsorpress.com](http://www.windsorpress.com)

### HOME IMPROVEMENTS

**BEST PRICE PAVING and Seal Coating:** Repairs, patch work, crack filling, 20% Discount, licensed and insured. Call 610-973-9086.

### DECKS DECKS Construction

Building decks, fences and ramps since 1979. Free estimates and design. Call Mark 610-589-9902 PA#047954. [www.decksdecksconstruction.com](http://www.decksdecksconstruction.com)

### PARADISE Construction Inc.

Concrete Masonry, Patios, Sidewalks, Steps, Landscape & Retaining Walls, Ponds & Pool Gardens, Stone Repointing and Brick, Footers, Porches, Basements, Driveways Call Anytime, 610-682-4150, Leave Message.

### HOME IMPROVEMENTS

**BASTIAN CARPENTRY & Remodeling LLC.** Windows, Doors, Decks, Porches, Siding, Aluminum Capping, Custom Interior Trim & Woodwork, Flooring, Cabinets, Basements Finished, New Construction & Restoration. 610-562-5326. Free Estimates. PA 047097

### STEPHEN LENDACKI,

Interior and Exterior Painting, Cabinet Refinishing and Restoration, Spraying, Property Maintenance, Wallpapering, Drywall Finishing and Repairs, Pressure Washing, Decks, Carpentry Repairs, Gutters, 30+ years experience, licensed and insured, lead certified PA10752, 610-987-6414.

## TERRY HARTMAN ROOFING CONTRACTOR

Residential and Commercial Roofs  
ROOF REPAIR  
NEW ROOFS  
SEAMLESS SPOUTING



- FULLY INSURED
- FREE ESTIMATES
- ON REPLACEMENT ROOFS

Quality Service Since 1972  
P.O. Box 56, Mertztown  
**610-395-3889**  
PA20597

## Blue Mountain Chimney Sweep

610-285-2081

- Chimney Liners
- Brick/Stone Pointing/Restoration
- Teardowns & Rebuilds
- Chimney Cleaning
- Relining Specialist
- Masonry Waterproofing
- Fireplace Restorations
- Repointing
- Masonry Repairs
- Chimney Caps & Dampers
- Inspections
- Flame Wood Stoves & Inserts



## QUALITY PUBLIC AUCTION

ANTIQUES & FURNITURE, BISQUE DOLLS, 100+ TOOTSIE TOYS, PEDAL CAR, MOWER, CHIPPER, ROTOTILLER & TOOLS  
Monday, October 31, 2016 at 1:00 P.M.

Location: Indoors at the Leesport Farmers Market Banquet Hall, 312 Gernants Church Road, Leesport, PA.

3-dr. 1-pc. corner cupboard, marble-top Victorian curio cab., 1-dr. low dry sink, side-by-side, Karastan rug set, Vict. sofa, tavern tbl., round marble-top coffee tbl., reed rckr., marble-top tbl., mahog. breakfront/desk combo, marble-top washstands, oak standing 1-dr. cab., park bench, wrought iron patio furn., set of 6 - 1/2-spindle deco. chairs, spinning wheel, sm. folding screen & dressing screens, drying racks, child's wicker settee, bucket bench, sm. 1 dr./open cupboard, flow blue, asst. antq. clocks, satin glass kero. lamp, banquet lamp, ABC Sampler, dec. stoneware, China tea set, jardiniere & stand, birdcage & stand, butter churn, asst. china pcs., Byers' Choice dolls, canvas peacock pntd. by A. Landsberg, 2 lg. bisque dolls, pewter tankards & plates, Buddy L fire trks., Am. Railway express trk., metal dump body trk., Hess trks., 100+ Tootsie toys, Vict. ash box, #9923 Stream Line elec. train set by Louis Marx & Co., Keystone Sprinkler tank trk., Sonny Parcel Post trk., pedal car, peg bench, document box, stoneware mugs, candle box, spice set, ice cream scoop, rolling pins, tinware, cookie cutters, agate batter bucket, General Store metal bag/string holder, wheelbarrow, asst. hand & grdn. tools, Crafts. miter saw, Central machinery drill press, Troy-Bilt rear tine SHP rototiller, Kees walk-behind mwr., Crafts. self-propelled mwr., Sears 3-hp air compressor, ext. ladders, Tomahawk chipper/shredder. **This is a one-owner collection w/beautiful & clean merchandise.** Terms: Cash or PA check day of auction. Preview starts 11:00 AM.

**WAGNER AUCTION SERVICE** Auction For: **NANCY Dennis & Tracy Wagner Auctioneers** **SCHEFFLER AU-001427-L, AU-003172-L** & **The Late RAYMOND SCHEFFLER**  
[www.wagnerauctioneers.com](http://www.wagnerauctioneers.com)  
610-562-7445 or 610-741-3828

## PUBLIC NOTICE

Notice is hereby given that on or after Thursday, October 27, 2016, 9:00 am at: East Penn Self Storage 3801 Allen Street Emmaus, PA 18049 610-965-7686

The undersigned, East Penn Self Storage, will sell at Public Lien Sale by competitive bidding, in accordance with the Pennsylvania Self-Storage Act, in an attempt to satisfy owner's lien, the personal property heretofore stored with the undersigned by:

454 - Rhoda  
492 - Hill  
204 / 2041 - Grundstrom  
431504 - Wolf  
337 / 341 - L. Massini



**"Is your grass and leaf collection a chore?"**

## We have the Solution!



**TRAC VAC**  
Pick up grass and leaves while you ride. With over 40 models, ask us how to choose the perfect one for your yard.

**LESS WORK BETTER RESULTS!**

## CANNS-BILCO

OUTDOOR POWER EQUIPMENT  
125 E PENN AVE ALBURTIS PA 18011  
**484-232-7333**  
[www.canns-bilco.com](http://www.canns-bilco.com)



READER'S  
**Recipe**



**TOASTED PUMPKIN SEEDS WITH SUGAR & SPICE**

- 1 C. Raw Pumpkin Seeds, Rinsed & Dried
- 6 Tbls. White Sugar, Divided
- 1/4 Tsp. Salt
- 1/2 Tsp. Pumpkin Pie Spice
- 1 Tbl. Olive Oil
- Add All ingredients to list

Preheat the oven to 250 degrees F (120 degrees C). Spread pumpkin seeds in a single layer on a baking sheet. Toast for 45 minutes, stirring occasionally, until dry and toasted. Larger seeds may take longer. In a large bowl, stir together 2 tablespoons of white sugar, salt and pumpkin pie spice. Set aside. Heat the oil in a large skillet over medium-high heat. Add the pumpkin seeds and sprinkle the remaining sugar over them. Stir with a wooden spoon until the sugar melts, about 45 seconds. Pour seeds into the bowl with the spiced sugar and stir until coated. Allow to cool before serving. Store in an airtight container at room temperature.

Send your recipes to: *The Windsor Press, Inc.*  
6 N. Third St., PO Box 465, Hamburg, PA 19526-0456  
Fax: 610.562.2770 or E-mail: [display@windsorpress.com](mailto:display@windsorpress.com)



**BERKS COUNTY'S FRESHEST SEAFOOD STORE**  
Always Making Sustainable Choices



Hours: Mon.-Fri.  
7 AM to 6 PM;  
Sat. 7 AM to 5 PM;  
Sun. 10 AM to 3 PM  
Accepting Access/Quest Card

Store 610.926.2025  
Fax: 610.926.3696  
Purchasing & Wholesale  
610.926.2117  
8472 Allentown Pike  
Blandon, PA 19510



**FREE SOUP** w/Purchase & Ad per 100  
**Littleneck Clams** \$2175 per 100  
400 ct. bag \$8000  
Honestly, You Know Who Is #1

Whole - Will Cut For Free <b>Choice New York Strips</b> \$695 lb.	<b>Swai Fillets</b> \$395 lb. Stuffed w/Crabmeat \$495 ea.	<b>Stewing Oysters</b> \$895 doz. Cape Charles 1/2 Shell Oysters 25/\$1995	Whole - Will Cut For Free <b>Filet Mignon</b> \$1150 lb.
Monday & Tuesday Only <b>One FREE lb. Durum Semolina Linguini</b> With Every \$20.00 Purchase A fantastic start to your seafood dish!	<b>Fresh Lump Crabmeat</b> \$1095 lb.	<b>Crabfest</b> JUMBO LUMP \$1595 lb. LUMP \$975 lb. SPECIAL \$775 lb. CLAW \$675 lb. Pasturized	<b>Seafood Gumbo</b> \$600 qt. OR 2/\$1000

Specials For Monday, October 24 thru Sunday, October 30

*Once Upon A Time....*

There was an owner of a very successful hot dog stand. This owner built his business by having the best hot dogs around and by letting his customers know about them through extensive advertising. His business was so successful that he was able to send his son to a prestigious Ivy League school where his son was studying to receive his M.B.A.

One day the son came home for a break and promptly questioned his father "Dad, don't you know that there is a recession going on out there?" The father replied that his business was going very well, but the son persisted telling his father "Dad, you've got to cut back." So the father, figuring his son knew all about business, followed the son's advice. He promptly cut his advertising budget and then cut his hot dog & bun orders. Before long, business in fact did slow down. So the father replied to the son "You were right, son. Business is terrible. There is a recession going on out there."



SINCE 1958  
6 N THIRD STREET  
PO BOX 465  
HAMBURG, PA 19526-0465  
610-562-2267 or 1-800-562-5521  
FAX: 610-562-2770  
Email: [display@windsorpress.com](mailto:display@windsorpress.com)  
[www.windsorpress.com](http://www.windsorpress.com)

**PERSONAL PROPERTY & REAL ESTATE AUCTION**

Saturday, Oct. 29, 2016 at 9:00 AM (Preview 7:00 AM)  
Location: 7661 Carls Hill Rd., Zionsville, PA 18092-2504.  
**Personal Prop. 9:00-Welders:** Lincoln Tig 175; ESAB Mig 4HD; Miller 330; oxygen/acetylene, 7500W generator; Husqvarna rototiller; Porta bands; drill press; anvil; power/hand tools; hardware; Kobalt tool cabinets; other; engine hoist. **Butchering items:** Hobart meat saw, Lem sausage stuffer/other, scrapple pots, smokehouse; stainless; much more. **Hunting/Fishing Items:** Centurion 40-gun safe, 250+ traps & related items. **11:30:** 1993 Case Extendahoe backhoe/loader, 4x4, 5611 hours. **R.E. 12:00:** 27+/- acres incl. 2 1/2-story frame Victorian farmhouse, bank barn, butcher shop, etc. (Terms of sale on auctionzip.com #1888)

For more details please call 484-375-8410; for photo details see [www.auctionzip.com](http://www.auctionzip.com) ID: #5475 and #1888 or [www.somersauctioneering.com](http://www.somersauctioneering.com).  
**P.P. Terms & Conditions:** 13% B.P. (3% disc. w/cash or check); Visa, MC, Discover, Cash or Check (w/valid ID). NO SALES TAX ON P.P.



Auctioneer: GREG P. SOMERS, AU003981L  
Real Estate offered in conjunction with Robert H. Clinton & Co. Inc., AY000093L

**MOTORCYCLES/ATV'S**

2011 Suzuki GSX-R600. Blue/white, 10,750 miles. Excellent condition, clean title. Upgraded exhaust, new tires, Puig tinted screen. Fantastic deal at \$6,750 firm. 610-820-9144.

FOR SALE: Harley Davidson Leather Motorcycle Jacket. Size 42 Reg. Good condition. \$45; 484-332-2653.

**MOTORCYCLES/ATV'S**

MOTORCYCLES WANTED: Before 1985. Running or not Japanese, British, European, American \$Cash\$ paid. Free appraisals! CALL 315-569-8094 Email pictures or description to: Cyclers toration@aol.com(\*199249)

**Windsor Press, Inc.**  
**OFFICE HOURS** Mon. - Fri. 8am to 5pm



**You Can Now Read The East Penn Valley and Northern Berks Merchandisers Online!**

Go to...  
[www.windsorpress.com](http://www.windsorpress.com)  
[www.epvmerchandise.com](http://www.epvmerchandise.com)  
[www.nbmerchandise.com](http://www.nbmerchandise.com)

# Construction BLOWOUT SALE!

**OPEN FOR BUSINESS!** **PRICES NEVER LOWER!**

**MUST MOVE INVENTORY!**



**SAVE THOUSANDS**  
**NO DEALERS**  
**PRICES BELOW BOOK**



## MASSIVE INVENTORY = BEST SELECTION EVER!

**2001 FORD MUSTANG GT**  
 Stock #B16491B, "Convertible"  
  
**SAVE \$2,000**  
**Now \$7,990**

**2003 CHEVY MONTE CARLO SS**  
 Stock #G16164A, Only 23K Mi., Competition Yellow, Loaded, Was \$13,990  
  
**SAVE \$1,000**  
**Now \$12,900**

**2010 DODGE CHALLENGER**  
 Stock #U4656A, Was \$14,990  
  
**SAVE \$1,000**  
**Now \$13,900**

**2012 CHEVY CAMARO SS2**  
 Stock #U4675 6.2, Loaded, Conv., 28K Mi., Was \$25,990  
  
**SAVE \$1,000**  
**Now \$24,900**

### GREAT VEHICLES UNDER \$15,000

2006 Cadillac CTS Sdn. Sporty	\$8,777
1998 Chevy Silverado	\$8,900
Great Shape, Low Miles, Must See	
2004 GMC Canyon 4x4	\$8,900
2008 Nissan Altima	\$8,900
2010 Pontiac G6, GT Sporty, Low Miles	\$10,900
2011 Buick Regal CXL Sdn.	\$11,800
2012 Dodge Avenger Low Miles	\$11,900
2008 GMC Sierra Reg. Cab, Long Bed	\$12,888
2012 Chevy Cruze Sdn.	\$12,900
Stick Shift, Sporty, 19,000 Miles	
2014 Dodge Dart SXT Stick, 25,000 Miles	\$12,900
2010 Buick Lucerne	\$12,900
Luxury For	
2007 Jeep Cherokee 4x4 Low Miles	\$12,900
2013 Chevy Malibu LS	\$13,777
Only 34K Mi., Great On Gas	
2010 GMC Terrain SLE-2	\$13,800
2010 Buick LaCrosse Sdn. Luxury Car	\$13,888
2007 GMC ACADIA SLT	\$14,900
Leather, Loaded, 3rd Seat	

### IMPORTS

2015 VW Passat 23,000 Miles	\$18,777
2012 Toyota RAV4	\$18,900
AWD, 55,000 Miles	
2012 HONDA CRV EXL, Low Miles	\$19,777
2014 Audi A4	Save Thousands!
Quattro, Low Mi.	
2015 Acura TLX	Like New
Navigation, Loaded	
2013 Nissan Rogue AWD	Loaded!
2015 Subaru Outback	Save Thousands!
AWD, Low Miles	

### PICKUPS FOR LESS

2012 Dodge Ram Reg. Cab, Long Bed	\$19,800
2014 Toyota Tacoma	\$25,800
Only 12,000 Miles, Like New	
2013 Chevy Silverado LT 1500	\$26,888
Ext. Cab, 4x4, Was \$28,777, <b>SAVE \$2,000</b>	
2011 Chevy Silverado Z71	\$27,900
Crew Cab, Low Miles, Beautiful Shape	
2011 Chevy Avalanche LT	\$28,800
Leather, <b>SAVE \$1,000</b>	
2013 Toyota Tacoma	\$28,900
Crew, SR5, Loaded, 4x4, Great Looker	
2013 Chevy Silverado LT	\$29,888
Crew Cab, Only 45,000 Miles, Burgundy, Z71, <b>SAVE \$2,000</b>	
2014 Dodge Ram Hemi	\$29,900
Only 18,000 Miles, Chrome Pkg., <b>SAVE \$2,000</b>	
2013 Chevy Silverado Z71	\$30,900
Black, Ton. Cover, Steps, Loaded, Must See! Showroom Condition	
2013 Ford Lariat F-150	\$32,900
Loaded, Great Shape	

**SEVERAL MORE TO CHOOSE FROM**  
**2014, 2015, 2016 - ALL TYPES**  
**OVER 25 PICKUPS IN STOCK**  
**All Models, Greatest Selection Ever**

### CARGO & COMMERCIAL

2007 GMC Box Truck	\$14,900
Diesel, 14' Box, 12,000, Power Lift Gate	
2015 GMC Savana Cargo	\$19,800 & Up
3 To Choose From	
<b>2015 &amp; 2016 Ford Transit Cargo Vans</b>	
<b>Save Thousands!</b>	
<b>2016 Ram Promaster Cargo Vans</b>	
<b>Save Thousands!</b>	

### CADILLACS - LUXURY FOR LESS

2009 Cadillac CTS	\$16,800
White Diamond, Sport Model, Only 49,000 Mi., <b>SAVE \$2,000</b>	
2011 Cadillac CTS Sdn	\$17,900
Sport Model, Low Miles, <b>SAVE \$2,000</b>	
2010 Cadillac CTS	\$18,800
Sport, Luxury, Crystal Red, 42,000 Miles	
2013 Cadillac ATS	\$22,800
Only 37,000 Miles, AWD, <b>SAVE \$2,000</b>	
2013 Cadillac CTS Cpe.	\$29,900
AWD, Navigation, Roof, 19,000 Mi., <b>\$25,000 Under MSRP</b>	
2012 Cadillac Escalade AWD	\$38,888
White Diamond & Black, 2 To Choose From	
<b>Over \$30,000 Off Original MSRP</b>	

**CADILLAC SRX**  
**Starting at \$17,900**  
 AWD, 5 To Choose From

**CADILLAC XTS Luxury Models**  
**Up To \$25,000 Under Original MSRP**  
 5 To Choose From

**2015 CADILLAC Escalades**  
**\$30,000 Under Original MSRP**  
 Navigation, DVDs Loaded, 2 To Choose From

### JEEPS

2010 Jeep Wrangler	\$21,900
Hard Top, Low Miles, <b>SAVE \$1,000</b>	
2011 Jeep Wrangler	\$23,900
4 Door, Low Miles, <b>SAVE \$1,000</b>	
2016 Jeep Renegade	\$24,777
Low Miles, Like New ...	
2013 Wrangler Rubicon	Save Thousands!
Burg., 2 Dr., Oversized Tires & Custom Whls., w/6.0, Great Looker	

**OVER 20 SUVs IN STOCK from \$8,900 on up**  
 3rd Seaters, Leather, Cloth, Best Selection Around  
**Save Thousands!!!**



**Berks County's Exclusive Buick, Cadillac, GMC & Preowned Superstore**  
 Monday thru Thursday till 8:00 pm • Friday till 6:00 pm • Saturday till 5:00 pm  
**Rt. 222 & 662 In Fleetwood**  
**• 610-683-8800**  
**• www.kutztownauto.com**



# Have you seen me? Female Beagle/Basset Mix



**\$3,000  
REWARD**

**Scared DO NOT chase**



**Call/text with ANY information  
610-496-5017**